



**2-wire loop powered toxic and
Oxygen gas detector for use in
potentially explosive atmospheres
- explosion proof and intrinsically
safe versions**

Series 3000 MkII and MkIII



Reliable detection

- Proven electrochemical sensing technology
- Uses Surecell™ electrochemical cells, ideal for hot and humid environments
- Long-life sensing elements
- Patented 'Reflex' sensing element verification diagnostics

Reduced installation costs

- Integral surface mounting lugs
- Optional horizontal or vertical pipe mounting bracket
- Flameproof transmitter allows field wiring to be run along with other non-IS instruments
- Plug-in sensor removes wiring
- Can be retrofitted in place of Series 2000

Reduced commissioning costs

- Sensor recognition feature auto configures transmitter
- Non-intrusive configuration
- Plug and play factory configured sensors

Reduced maintenance costs

- IS sensor connection permits hot swap, reducing downtime
- User programmable calibration frequency
- Integral fault diagnostic software
- Menu/icon driven calibration procedure

Regulatory compliance

- European (ATEX)
- US (UL)
- Canadian (c-UL)
- South America (Inmetro)
- International (IECEX)

Range of optional accessories

- Remote sensor mounting kit
- Duct mounting kit (for H₂, CO and H₂S only)
- Calibration cup to apply test gas
- Collecting cone

Typical applications

- Exploration and drilling platform
- Production platforms
- Onshore oil and gas terminals
- Refineries and chemical plants
- Power plants
- Waste water facilities
- Utilities

The Series 3000 range of transmitters provide comprehensive monitoring of toxic and Oxygen gas hazards in potentially explosive atmospheres. Suitable for mounting both indoors and out, they are available in two versions and offer excellent versatility. The MkII is contained in a flameproof housing, has an intrinsically safe sensor connection and is for use in predominantly Zone 1 applications. However with the use of the optional remote mounting kit the sensor of the MkII can be mounted in a Zone 0 environment. The MkIII is for use with a separate suitable IS barrier allowing the complete transmitter to be used in Zone 0 applications.

These low powered gas detectors all feature a loop powered 4-20 mA connection, making them ideal for both new and retrofit installations. Users can configure the detector through the use of the easy to read LCD and intuitive interface while fault diagnostic software and a programmable calibration period greatly simplify maintenance procedures.



The intrinsically safe smart sensors are supplied pre-configured and can be 'hot swapped' without having to remove power to the detector, saving time and money during commissioning and routine servicing. A remote sensor mounting kit is available that allows the sensor to be mounted up to 15m (50ft) from the transmitter, making it ideal for operation in areas that are difficult to access.

Series 3000 is supplied with all necessary accessories for easy installation. The detector can be wall mounted using the integral mounting lugs or pipe mounted (horizontal or vertical) using the optional pipe mounting kit. Electrical installation is made using the 2 x M20 cable entries (ATEX/IECEX version) or 2 x 3/4"NPT conduit entries (UL/c-UL versions). A suitable blanking plug is also supplied to seal any unused entries. A weatherproof cap is included for use in the harshest outdoor conditions.

Installation



Mechanical Installation Options

Series 3000 MkII and MkIII are designed for use in potentially explosive atmospheres. As such, installation should follow national guidelines using suitable mechanically protected cable and glands (M20 or ¾" NPT) or conduit (¾" NPT). Use 0.5mm² (20AWG) to 2.0mm² (~14AWG) cross sectional area cable as needed to ensure minimum operating voltage at the detector, depending on installed cable length. Various accessories are available for different applications.

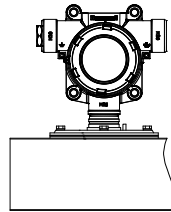

Duct Mount

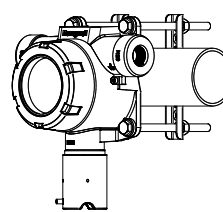

Pipe Mounting

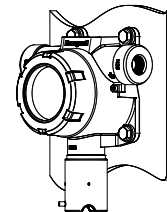

Wall Mount

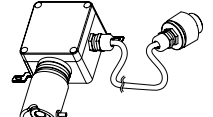

Remote Mounting

Dimensions

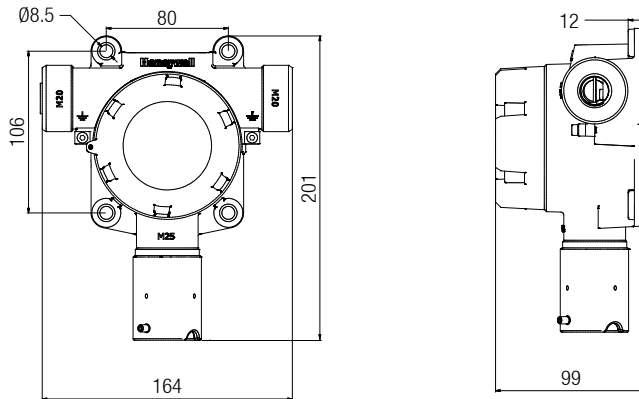

Remote Mounting Arrangement

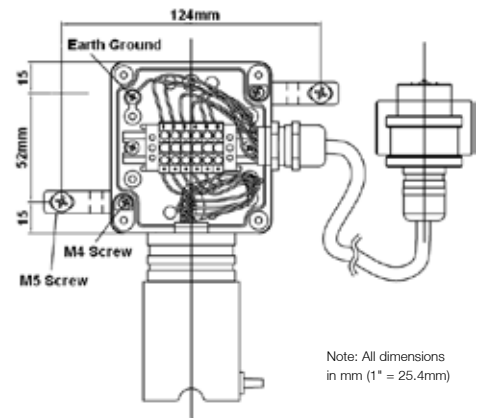

Wiring Schematics Series 3000 MkII

Detector supply V_d

- 17Vdc (min) to 32Vdc (max)

Maximum detector signal I_m

- 22mA (over range)

Cable resistance R_c

- Subject to cable type

Load resistor of control panel R_L

- Assumed 33 Ω (min) or 250 Ω (max)
- Subject to controller manufacturer

Controller supply voltage V_c

- Subject to controller manufacturer
- Assumed nominal of 24Vdc

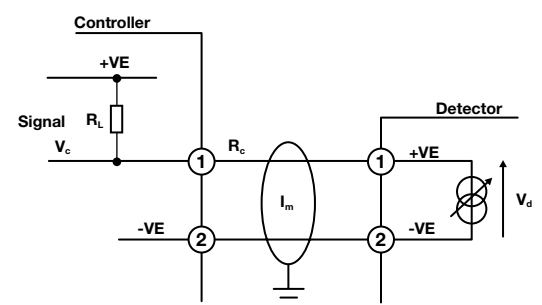
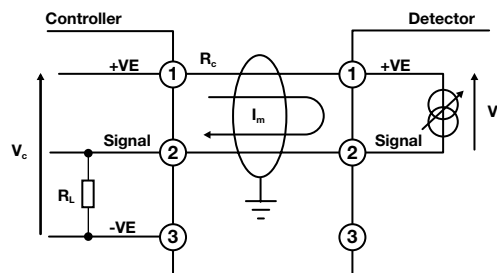

Typical Maximum Installed Cable Lengths Series 3000 MkII

The maximum cable length between a controller and detector is dependent upon:

- The minimum guaranteed supply voltage to the detector at the controller (V_c).
- The minimum operating voltage of the detector (V_d)
- The maximum current draw of the detector (I_m)
- The input impedance of the controller (R_L)
- The resistance of the cable (R_c)

Using the example values, the table opposite shows typical cable lengths.

For a specific application, the cable manufacturer's resistance data for a specific cable type must be used.

A cable length calculation formula can be found in the product technical manual.

Series 3000 MkII Maximum Cable Length shown in km (mi)

Cable Size	Cable Resistance R_c Ω /km (Ω /mi)	Cable distance km (mi) where the Input Impedance $R_L = 33\Omega$	Cable distance km (mi) where the Input Impedance $R_L = 250\Omega$
0.5mm ² (20AWG*)	36.8 (59.2)	3.9 (2.4)	0.9 (0.6)
1.0mm ² (17AWG*)	19.5 (31.4)	7.3 (4.5)	1.7 (1.1)
1.5mm ² (16AWG*)	12.7 (20.4)	11.2 (7.0)	2.7 (1.7)
2.0mm ² (14AWG*)	10.1 (16.3)	14.1 (8.8)	3.4 (2.1)

*Nearest equivalent

Installation



Wiring Schematics Series 3000 MkIII

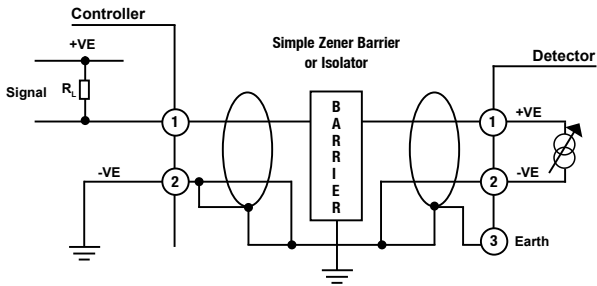

Single Barrier Schematic

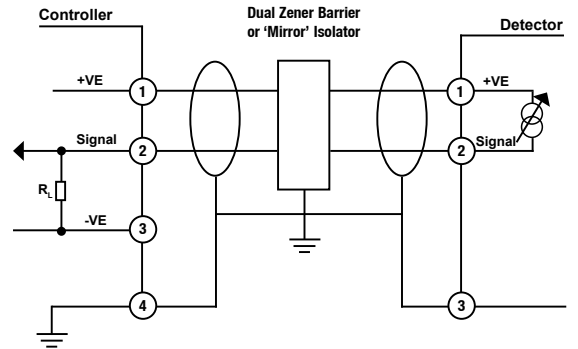

Dual Barrier Schematic

Series 3000 MkIII Cable Length

The limiting factors in calculating maximum cable lengths when using barriers and isolators are the total capacitance and inductance. Barriers and isolators have a fixed amount of capacitance and inductance that can be connected to their outputs. The cable between the field device and barrier/isolator will have a value for capacitance and inductance per metre or kilometre that will be available from the manufacturer or supplier.

To calculate the maximum cable lengths, calculate the total capacitance and inductance for the length of cable, add any capacitance or inductance due to the field device (in the case of Series 3000 MkIII capacitance and inductance = 0). The resulting totals should not be greater than the value shown for the barrier or isolator.

Suggested barriers and isolators Series 3000 MkIII

Listed below are some suggested barriers and isolators for use with Series 3000 MkIII.

- MTL7728+ (single channel zener barrier)
- MTL7787+ (2-channel zener barrier)
- MTL5042 (Galvanic Isolator)
- Pepperl+Fuchs KFD2-STC4-EX1 (Galvanic Isolator)

Note: It is up to the user to ensure that the barrier or isolator used is suitable for their application.

Electrical Connections

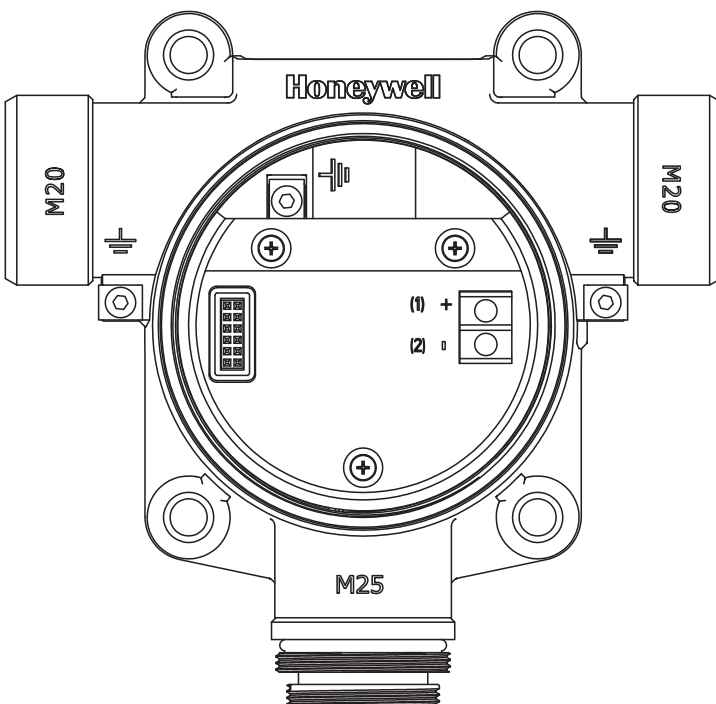

Terminal Number	Detector Terminal	Controller Connection
1	+	+VE
2	-	Signal

Technical Summary



Series 3000 MkII and MkIII Detector

Use Rugged and reliable gas detector for the protection of personnel from toxic and Oxygen gas hazards. MkII version suitable for use in Zone 1, 2, 21 or 22 hazardous areas and North American Class I and II Division 1 or 2 areas. MkIII version suitable for use in Zone 0, 1, 2, 20, 21 or 22 applications.

Detectable Gases

Gas	Formula	Selectable Full Scale Range	Default Range	Operating Temperature**	
				Min	Max
Oxygen	O ₂	25.0% / Vol only	25.0%Vol	-30°C / -22°F	55°C / 131°F
Hydrogen Sulphide	H ₂ S	10.0 to 50.0ppm	15.0ppm	-40°C / -40°F	55°C / 131°F
Hydrogen Sulphide	H ₂ S	50 to 500ppm	100ppm	-40°C / -40°F	55°C / 131°F
Carbon Monoxide	CO	100 to 500ppm	300ppm	-40°C / -40°F	55°C / 131°F
Sulphur Dioxide	SO ₂	5.0 to 20.0ppm	15.0ppm	-40°C / -40°F	55°C / 131°F
Ammonia*	NH ₃	50 to 200ppm	200ppm	-20°C / -4°F	40°C / 104°F ¹
Ammonia*	NH ₃	200 to 1,000ppm	1,000ppm	-20°C / -4°F	40°C / 104°F
Chlorine	Cl ₂	5.0 to 20ppm	5.0ppm	-10°C / 14°F	55°C / 131°F
Chlorine Dioxide	ClO ₂	1.00ppm only	1.00ppm	-20°C / -4°F	55°C / 131°F
Nitric Oxide	NO	100ppm only	100ppm	-20°C / -4°F	55°C / 131°F
Nitrogen Dioxide	NO ₂	5.0 to 50.0ppm	10ppm	-20°C / -4°F	55°C / 131°F
Hydrogen	H ₂	1,000ppm only	1,000ppm	-20°C / -4°F	55°C / 131°F
Hydrogen	H ₂	9,999ppm only	9,999ppm	-20°C / -4°F	55°C / 131°F
Hydrogen Chloride	HCl	10.0 to 20.0ppm	10ppm	-20°C / -4°F	40°C / 104°F
Hydrogen Cyanide	HCN	30.0ppm only	30.0ppm	-20°C / -4°F	55°C / 131°F
Hydrogen Fluoride	HF	12.0ppm only	12.0ppm	-20°C / -4°F	55°C / 131°F
Phosphine	PH ₃	1.2ppm only	1.2ppm	-20°C / -4°F	40°C / 104°F
Fluorine	F ₂	4.00ppm only	4.00ppm	-20°C / -4°F	55°C / 131°F
Ozone	O ₃	0.400ppm only	0.400ppm	-20°C / -4°F	55°C / 131°F
Ethylene Oxide	ETO	20.0 to 50.0ppm	25.0ppm	-20°C / -4°F	55°C / 131°F



Electrical

Connections and Power	MkII	MkIII
	2-wire loop powered 17Vdc (±10%) to 32Vdc (max) 22mA max. over range	2 wire loop powered 10Vdc (±10%) to 30Vdc (max) 22mA max. overrange
		Entity parameters for Barrier Selection: V _{max} /U _i = 30Vdc I _{max} /I _i = 125mA P _{max} /P _i = 1.2W L _i = 0mH C _i = 0µF

Recommended Cable	2-wire with screen (90% coverage) or conduit 0.5mm ² (20AWG) to 2.0mm ² (14AWG)
Signal	0-100% FSD 4-20mA Fault = 3mA Calibration due selectable off or 3mA Max. over range 22mA Inhibit (toxic sensors) = Selectable 3mA or 4mA Inhibit (Oxygen sensors) = Selectable 3mA or 17.4mA

Construction

Material	Transmitter: Epoxy painted aluminium alloy LM25 or 316 Stainless Steel, Sensor: 316 Stainless Steel with PTFE filter
Maximum Dimensions	164mm x 201mm x 99mm (6.4" x 7.9" x 3.9")
Weight	Aluminium alloy LM25: 1.7kg (3.75lbs.) Stainless Steel 316: 3.7kg (8.16lbs.)

Environmental

IP Rating	IP66 (EN 60529), NEMA 4X
Certified Temperature	ATEX/IECEX: -20°C to +55°C (-4°F to +131°F) (MkIII -40°C to +55°C (-40°F to +131°F)) UL/c-UL: -40°C to +55°C (-40°F to +131°F)
Operating Humidity	Continuous 20-90% RH (non-condensing) Intermittent 0-99% RH (non-condensing)
Operating Pressure	90-110kPa
Storage Conditions	15°C to 30°C (59°F to 86°F), 30-70% RH (non-condensing)

*Suitable for applications without NH₃ ambient background concentrations only.

**When operating in Hazardous Area applications the detector must not be operated outside the certified temperature range. See Certification details for UL, c-UL and ATEX/IECEX certified temperature ranges.

¹ +55°C / 131°F intermittent.

Technical Summary and Ordering Information



Certification

MkII

Transmitter:

UL/c-UL: Class I, Div. 1 & 2, Groups B, C & D; Class II, Div. 1 Groups E, F & G, Class II, Div. 2, Groups F & G; Class I, Zone 1, Group IIB + H2 Hazardous Locations

ATEX: Ⓜ II 2 (1) GD Ex d [ia IIC Ga] IIB + H2 T4 Gb Ex t [ia IIIC Da] IIB T135°C Db

IECEX: Ex d [ia IIC Ga] IIB + H2 T4 Gb Ex t [ia IIIC Da] IIB T135°C Db

Remote Sensor Accessory:

UL/c-UL: Class I, Division 1, Groups A, B, C and D Class II, Divisions 1 and 2, Groups E, F and G Class 1, Zone 0, Group IIC; Class II, Zone 20

ATEX: Ⓜ II 1G D Ex ia IIC T4 Ga Ex ia IIIC T135°C Da

IECEX: Ex ia IIC T4 Ga Ex ia IIIC T135°C Da

MkIII

Transmitter:

UL/cUL Class I, Divisions 1 & 2, Groups A, B, C & D; Class II, Divisions 1 & 2, Groups E, F & G

ATEX: Ⓜ II 1 (1) GD Ex ia IIC T4 Ga Ex ia IIIC T135°C Da

IECEX: Ex ia IIC T4 Ga Ex ia IIIC T135°C Da

Remote Sensor Accessory:

UL/c-UL = Class I, Div. 1, Groups A, B, C & D; Class II Division 1 & 2, Groups E, F & G; Class 1, Zone 0, Group IIC; Class II, Zone 20

ATEX: Ⓜ II 1G D Ex ia IIC T4 Ga Ex ia IIIC T135°C Da

IECEX: Ex ia IIC T4 Ga Ex ia IIIC T135°C Da

Approvals

CE compliant in accordance with: ATEX Directive 94/9/EC, EMC Directive 2004/108/EC, EN 50270

Ordering Information

A complete assembly consists of two parts, a transmitter and sensor which must be ordered separately.

- Transmitter PN#: Two certified versions are available:
 - ATEX/IECEX approved version (Aluminium version part number S3KAL2, S3KAL3 Stainless Steel version part number S3KAS2, S3KAS3)
 - UL/CSA approved version (Aluminium version part number S3KUL2, S3KUL3, Stainless Steel version part number S3KUS2, S3KUS3)
 - Inmetro approved version (Aluminium version part number S3KNL2, S3KNL3, Stainless Steel version part number S3KNS2, S3KNS3)
- Sensor PN#: All certified ATEX, IECEX, UL, CSA (c-UL) with two digits to specify gas type and range:
 - e.g. S3KXXC1SS (C1 denotes Carbon Monoxide, with a default range of 0-300ppm and user configurable for ranges from 0-100ppm to 0-500ppm (in 100ppm steps))

Transmitter

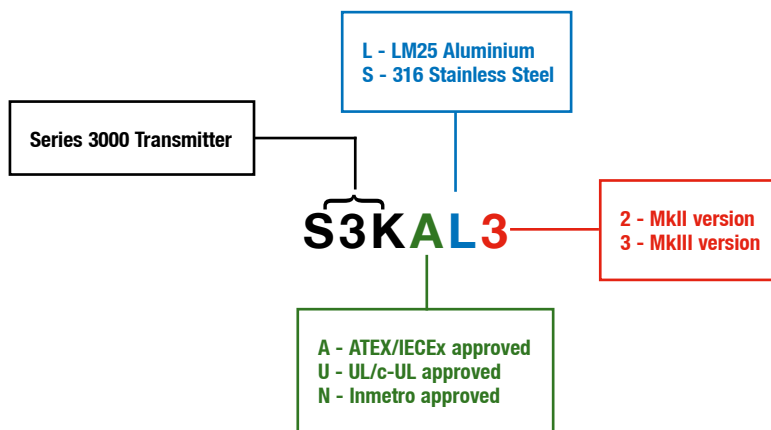

Sensor Part Numbers and Available Gases

S3KXS01SS	Oxygen (O ₂) 0-25% Vol
S3KXSC1SS	Carbon Monoxide (CO) 0-300ppm (default) 0-100 to 0-500ppm selectable
S3KXSC2SS	Carbon Monoxide (CO) 0-300ppm (default) 0-100 to 0-999ppm selectable
S3KXSH1SS	Hydrogen Sulphide (H ₂ S) 0-15ppm (default) 0-10 to 0-50ppm selectable
S3KXSH2SS	Hydrogen Sulphide (H ₂ S) 0-100ppm (default) 0-50 to 0-500ppm selectable
S3KXSL1SS	Chlorine (Cl ₂) 0-5ppm (default) 0-5 to 0-20ppm selectable
S3KXSS1SS	Sulphur Dioxide (SO ₂) 0-15ppm (default) 0-5 to 0-20ppm selectable
S3KXSX1SS	Chlorine Dioxide (ClO ₂) 0-1ppm only

Ordering Information Continued



Ordering Information Continued

S3KXSM1SS	Nitrogen Monoxide (NO) 0-100ppm only
S3KXSN1SS	Nitrogen Dioxide (NO ₂) 0-10 ppm (default) 0-5 to 0-50 ppm selectable
S3KXSG1SS	Hydrogen (H ₂) 0-1000ppm only
S3KXSG2SS	Hydrogen (H ₂) 0-10,000 only
S3KXSR1SS	Hydrogen Chloride (HCl) 0-10ppm (default) 0-10 to 0-20ppm selectable
S3KXSA1SS	Ammonia (NH ₃) 0-200ppm (default) 0-50 to 0-200ppm selectable
S3KXSA2SS	Ammonia (NH ₃) 0-1000ppm (default) 0-200 to 0-1,000ppm selectable
S3KXSY1SS	Hydrogen Cyanide (HCN) 0-30 ppm only
S3KXSF1SS	Hydrogen Fluoride 0-12 ppm only
S3KXSP1SS	Phosphine 0-1.2 ppm only
S3KXSU1SS	Fluorine (F ₂) 0-4.00ppm only
S3KXSZ1SS	Ozone (O ₃) 0-0.400ppm only
S3KXSE1SS	Ethylene Oxide (ETO) 0-25.0ppm (default) 0-20.0 to 0-50.0ppm selectable

Shipping Details

Shipping carton dimensions	315mm (12.4") (L) x 230mm (9.0") (W) x 115mm (4.5") (D)
Approximate weight	Aluminium alloy LM25 : 1.7kg (3.75lbs.) Stainless Steel 316 : 3.7kg (8.16lbs.)

Optional Accessories

SPXCMTBR	Pipe Mounting Bracket
SPXCSDP	Sunshade/Deluge Protection
S3KCAL	Calibration gas flow housing
S3KCC	Collecting cone (for use when detecting Hydrogen gas only)
S3KDMK	Duct mounting kit (for use when detecting O ₂ , CO, H ₂ S or H ₂ gas)
S3KRMK	ATEX/UL/c-UL approved remote sensor mounting kit (includes enclosure with sensor socket, 15m (50 feet) of digital cable and glands, transmitter cable plug, mounting screws)

Calibration Gases

Contact Honeywell Analytics representative



Honeywell Analytics Gas Detection



Honeywell Analytics is able to provide gas detection solutions to meet the requirements of all applications and industries. Contact us in the following ways:

Headquarters

Europe, Middle East, Africa

Life Safety Distribution AG
Javastrasse 2
8604 Hegnau
Switzerland
Tel: +41 (0)44 943 4300
Fax: +41 (0)44 943 4398
gasdetection@honeywell.com

Customer Service:

Tel: 00800 333 222 44 (Freephone number)
Tel: +41 44 943 4380 (Alternative number)
Fax: 00800 333 222 55
Middle East Tel: +971 4 450 5800 (Fixed Gas Detection)
Middle East Tel: +971 4 450 5852 (Portable Gas Detection)

Americas

Honeywell Analytics Distribution Inc.
405 Barclay Blvd.
Lincolnshire, IL 60069
USA
Tel: +1 847 955 8200
Toll free: +1 800 538 0363
Fax: +1 847 955 8210
detectgas@honeywell.com

Asia Pacific

Honeywell Analytics
Asia Pacific
#701 Kolon Science Valley (1)
43 Digital-Ro 34-Gil, Guro-Gu
Seoul 152-729
Korea
Tel: +82 (0) 2 6909 0300
Fax: +82 (0) 2 2025 0388
India Tel: +91 124 4752700
analytics.ap@honeywell.com

Technical Support Centres

Honeywell Analytics Ltd.
4 Stinsford Road
Nuffield Industrial Estate
Poole, Dorset, BH17 0RZ
United Kingdom
Tel: +44 (0) 1202 645 544
Fax: +44 (0) 1202 645 555

Honeywell Analytics
ZAC Athélia 4 - 375 avenue du Mistral
Bât B, Espace Mistral
13600 La Ciotat
France
Tel: +33 (0) 4 42 98 17 75
Fax: +33 (0) 4 42 71 97 05

Honeywell Analytics
Elsenheimerstrasse 43
80687 München
Germany
Tel: +49 89 791 92 20
Fax: +49 89 791 92 43

Honeywell Analytics
P.O. Box-45595
6th Street
Musaffah Industrial Area
Abu Dhabi
UAE
Tel: +971 2 554 6672
Fax: +971 2 554 6672

EMEA: HAexpert@honeywell.com
US: ha.us.service@honeywell.com
AP: ha.ap.service@honeywell.com

www.honeywellanalytics.com
www.raesystems.com

Honeywell Analytics
Experts in Gas Detection



Please Note:

While every effort has been made to ensure accuracy in this publication, no responsibility can be accepted for errors or omissions. Data may change, as well as legislation, and you are strongly advised to obtain copies of the most recently issued regulations, standards, and guidelines. This publication is not intended to form the basis of a contract.

12113_H_Series 3000 MkII & MkIII_DS01057_V9_EMEA

05/15

© 2015 Honeywell Analytics

Honeywell

DSA Suppliers

Thank you for reading this. For pricing or further information, please contact us.

W: <https://dsasuppliers.com>

E: sales@dsasuppliers.com

P: +441158390391

Leading UK Supplier
Brand New & Genuine OEM Parts
Delivered Worldwide



Worldwide Delivery



1000+ Genuine Parts & Equipment

Please Note - The information, product designs & specifications in this document are subject to change without notice.
DSA Suppliers is not responsible for determining the suitability of this product.