



Satellite XT R Version

Including Options:
Extractive Module XT
Pyrolyzer Module XT

Section 1	Basic Operation	Page
1.1.....	Principle of Operation	1-1
1.2.....	Operating States	1-1
1.2.1	Monitoring Mode	1-1
1.2.2	Maintenance Mode	1-2
1.2.3	Warning Condition	1-2
1.2.4	Diagnostics	1-2
1.3.....	Menu structure.....	1-2
1.3.1	Maintenance Menu	1-2
1.3.2	Calibration Menu.....	1-2
1.3.3	Configuration Menu	1-2
1.4.....	Operational Elements	1-3
1.4.1	Keypad Functions.....	1-3
1.4.2	Graphic Display	1-3
1.5.....	Technical Specifications	1-4
Section 2	Installation and Start-up	
2.1.....	General Guidelines.....	2-1
2.2.....	Standard Mounting	2-1
2.3.....	Duct Mounting.....	2-3
2.3.1	Connecting the Sensor Extension to the Instrument	2-3
2.3.2	Mounting the Sensor Extension to the Duct	2-4
2.4.....	Wiring.....	2-5
2.5.....	Initial Start-Up	2-7
Section 3	Main Menu	
3.1.....	The Main Menu Screens.....	3-1
3.2.....	Main Menu - Monitoring.....	3-2
3.3.....	Main Menu - Maintenance	3-3
3.4.....	Main Menu - Calibration.....	3-4
3.5.....	Main Menu - Configuration	3-5
Section 4	Mantenimiento	
4.1.....	Sensor Service	4-3
4.2.....	Alarm Reset.....	4-4
4.3.....	Alarm/Warn Test.....	4-4
4.4.....	Device Infos	4-5
4.5.....	Sensor Infos.....	4-6
4.6.....	Reset Device	4-8
4.7.....	Service.....	4-8
Section 5 Calibration		
5.1.....	Gas Calibration	5-2
5.1.1	Zero Adjust	5-2
5.1.2	Span Adjust	5-3
5.2.....	Manual K-Factor	5-4

Section 6	Configuration	Page
6.1.....	Alarm Settings	6-3
6.1.1	Alarm 1	6-4
6.1.2	Alarm 2	6-7
6.2.....	Language.....	6-8
6.3.....	Date Format.....	6-8
6.4.....	Auto Selftest	6-9
6.5.....	Security.....	6-9
6.6.....	Password.....	6-10
6.7.....	Location	6-10
6.8.....	New Sensor Type	6-11
6.9.....	Gas Name.....	6-11
6.10.....	Relays.....	6-12
Section 7	Troubleshooting	
7.1.....	Warning and Fault Messages.....	7-1
7.1.1	Warnings.....	7-1
7.1.2	Faults	7-2
Section 8	Reference Information	
8.1.....	Sensor Order Information	8-1
8.2.....	Spares and Accessories.....	8-3
Section 9	Extractive Module XT - Option	
9.1.....	Principle of Operation	9-1
9.2.....	General Instructions.....	9-1
9.3.....	Safety Instructions	9-1
9.4.....	Instrument Design.....	9-2
9.5.....	Mounting.....	9-4
9.6.....	Tubing Connections.....	9-4
9.7.....	Sensor Replacement	9-5
9.8.....	Technical Specifications	9-6
Section 10	Pyrolyzer Module XT - Option	
10.1.....	Principle of Operation	10-1
10.2.....	General Instructions.....	10-1
10.3.....	Safety Instructions	10-1
10.4.....	Instrument Design.....	10-2
10.5.....	Mounting.....	10-3
10.6.....	Tubing Connections.....	10-4
10.7.....	Data Link.....	10-4
10.8.....	Power Connection	10-4
10.9.....	Technical specifications.....	10-5

This section provides a basic understanding of the instrument and its operation.

1.1 Principle of Operation

The Satellite XT R Version is a generic gas monitoring instrument for the detection of a wide range of hazardous gases. Power is supplied by a local 12 to 24 VDC power supply.

Target gas and measuring range depend on the type of sensor chosen. The sensor comes with the specific data in its internal data memory.

The Satellite XT R Version provides 3 single-pole single-throw relays for activation of external alarm devices. If the gas concentration exceeds the alarm levels, the instrument will activate the appropriate alarm relay and display an according message. A relay will also be activated in case of an instrument fault.

1.2 Operating States

There are four different operating states for the Satellite XT, Monitoring Mode, Maintenance Mode, Warning Condition, and Diagnostics. Depending on the selected operating state, the green status LED is either on, off, or flashing.

1.2.1 Monitoring Mode

The Monitoring Mode is the instrument's standard operating mode. In the Monitoring Mode, the instrument continuously monitors for hazardous gas concentrations and checks for alarm levels and instrument faults.

The instrument's self-diagnostics provides on-line preventive maintenance information identifying electronics or sensor problems, e.g. a sensor selftest is performed every 24 hours.

The green LED located above the <set> key is on.

The settings for Alarm Level 1 and Alarm Level 2 are automatically loaded when installing the sensor. Standard settings are 1x and 2x TLV (Threshold Limit Value) for the target gas. The Alarm Setup function in the Configuration Menu allows the user to change the alarm levels according to their specific requirements.

Whenever the concentration of the target gas exceeds the factory or user programmed alarm levels, the instrument will document this concentration alarm condition on its LCD Display and trigger the associated alarm relays.

1.2.1.1 Reset Alarms Function

Ex factory, Alarm 1 and Alarm 2 are preprogrammed "enabled" and "latching". In the event of a concentration alarm, the alarm indication with latching alarms will continue until the alarm is manually acknowledged by pressing the <set> key. Alarm Reset is not possible, if the alarm condition is still present.

1.2.1.2 Exiting the Monitoring Mode

Exiting the Monitoring Mode and entering the Maintenance Mode may be password protected. To prevent the instrument from manipulations by unauthorized personnel, it is recommended to enable this function (see Configuration Menu / Security Function).

- Password enabled:

Press the <esc> key to exit the Monitoring Mode and enter the password. The screen to enter the password is shown for one minute. During this period the Monitoring Mode remains active in the background. When the correct password has been entered, the instrument is in the Maintenance Mode, it is not monitoring, and the green LED is off.

- Password disabled:

Press the <esc> key to exit the Monitoring Mode. The instrument is now in the Maintenance Mode, the instrument is not monitoring, and the green LED is off.

1.2.2 Maintenance Mode

The Maintenance Mode indicates a complete absence of monitoring capability. The green status LED is off. Depending on the configuration the fault relay will be activated.

1.2.3 Warning Condition

A warning condition indicates that the instrument requires some attention, but the instrument is still able to monitor and operate as programmed.

The following will occur when the instrument detects a warning condition:

- the green status LED is flashing
- depending on the configuration the fault relay will be activated.

1.2.3.1 Reset Warning Condition

Press the <set> key to acknowledge and reset a Warning Condition.
Refer to Section 7, Troubleshooting for specific warnings.

1.2.4 Diagnostics

Instrument faults refer to a problem which prevents the instrument from operating properly and interferes with the ability to monitor or document concentration alarms.

If the instrument has detected an instrument fault, the fault relay is activated. The green status LED is off. The LCD display is flashing while indicating the specific fault message.

The instrument lists specific instrument responses to instrument faults. For information on the various fault messages and instructions on how to correct a fault condition, please refer to Section 7, Troubleshooting.

1.3 Menu structure

Besides the Monitoring Mode, there is also menu operation for the Satellite XT. Menu operation comprises three groups of functions, maintenance, calibration, and configuration. A password (if enabled) must be entered to exit the Monitoring Mode and to obtain access to the Main Menu.

1.3.1 Maintenance Menu

This function covers the realtime service procedures required for a regular maintenance of the instrument (e.g. sensor replacement).

1.3.2 Calibration Menu

Use the calibration function to dynamically calibrate the instrument with a known concentration of the target gas or manually by entering a new correction K-Factor.

1.3.3 Configuration Menu

Use this function to configure the Satellite XT and to program instrument and monitoring parameters to suit individual requirements.

! Note:

If the instrument was in the Monitoring Mode when last powered down, it will automatically return to the Monitoring Mode when power is restored.

1.4 Operational Elements

Located at the front of the instrument is the graphic display, the keypad consisting of six keys, and above the Set Key the green status LED.

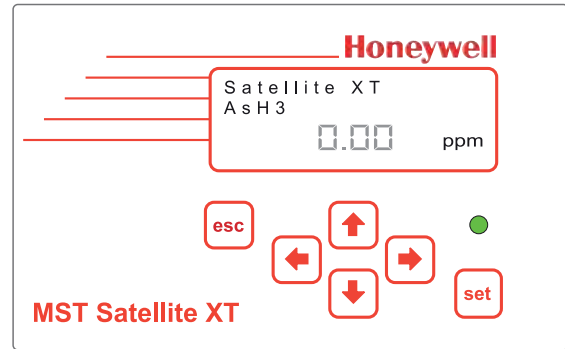

1.4.1 Keypad Functions

- o Escape Key <esc>
- o Set Key <set>
- o 4 Cursor Keys marked with an arrow, <up>, <down>, <left>, <right>.

In the Maintenance, Calibration, and Configuration Menu, these keys provide the following functions:

To move forwards and backwards in the menus, use the cursor keys <down> and <up>. Select a function by pressing the <set> key.

To enter text or figures, use the cursor keys <left> and <right> to reach the desired cursor position. Use the cursor keys <up> and <down> to select the letter, figure, or sign you wish to enter. Bring the cursor to the next position, select the next letter, figure, or sign. After entering the complete text, use the <set> key to confirm the changes. If you do not want to save the changes, abort by pressing the <esc> key.

1.4.2 Graphic Display



Depending on the operating mode the structure of the graphic display is different. Three basic versions are illustrated and explained below. A detailed description is given in the according sections.

Display Structure for Monitoring Mode

- Line 1 offers the possibility to enter a user specific description, e.g. monitoring location (max. 13 spaces; the name of the instrument is entered here when delivered).
- Line 2 shows the name of the gas monitored.
- Line 3 indicates the actual gas concentration and the concentration unit. Gas name and concentration unit are data stored in the memory of the sensor installed.

Display Structure for Menu

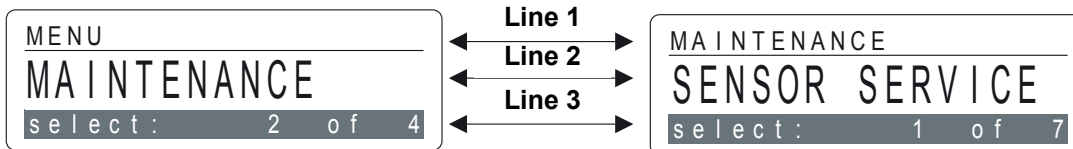

Line 1 shows the actual position in the menu. In the left example the actual position is Main Menu, in the right example it is the Sub-Menu Maintenance.

Line 2 shows one of the selection possibilities.

Line 3 shows the number of the selection possibility presently displayed and indicates also the total of selection possibilities available in this menu.

1.5 Technical Specifications

Power Requirements

voltage	12 - 24 VDC (18 VDC minimum when using the Extractive Module)
consumption	Max. 1.4 W

Wiring

power	2-wire shielded cable 2x0.5 mm ² / 20.4 AWG (approx. 2 m delivered with instrument)
relay contacts	6-wire shielded cable 6x0.25 mm ² / 23 AWG (approx. 3 m delivered with instrument)

Relay Outputs

contacts	3 x SPST (single-pole single-throw)
max. ratings	250 VAC / 30 VDC, 2 A

Graphic Display

122 x 32 dots with backlight

Status LED

Green

Keypad

6 touch-sensitive membrane function keys

Physical Dimensions

size	145 x 95 x 50 mm (L x W x H) 5.7" x 3.7" x 2.0" (L x W x H)
weight	620 grams 22 ounces

Mounting

special mounting plate
(delivered with instrument)

Housing Protection Class

IP 52 option: IP 65

EMC Directive 2004/108/EC

EN 50270

Operating Conditions

temperature	-20 °C ... +40 °C -4 °F ... +104 °F
pressure	700 ... 1300 hPa
humidity	20 ... 90 % r.h.

Part Number

Satellite XT R	9602-0505
Satellite XT R, IP 65	9612-0505

This section explains installation and initial start-up procedures.

2.1 General Guidelines

Please consider the aspects indicated below before locating the instrument.

The property of the target gas (lighter or heavier than air) must be considered. The instrument should be mounted as close to the monitoring location as possible and should be easily accessible for operation and maintenance. For narrow monitoring locations or duct mounting a sensor extension with a standard length of 2m (6 feet) is available as an option.

The optimum position to mount the instrument is in an upright position on a flat surface. If the instrument is used for ambient air monitoring, ensure that the sensor is facing downwards. For personal monitoring applications the instrument should be mounted at head level.

Ensure that the area immediately surrounding the instrument is free from objects that might hinder free flow of air. The instrument should be installed away from any possible liquid sources, extreme dust and dirt sources and should be protected against rain and sunlight. An instrument version protection class IP 65 is available for outdoor applications.

A junction box is recommended to connect the instrument to external control systems. A distance of 2 m (6 feet) must not be exceeded.

Regarding the power requirements and operating conditions, please follow the specifications indicated in Section 1, Technical Specifications, for wiring instructions refer to Section 2, Wiring.

The sensors should be stored in a cool, dry place when not in use.

2.2 Standard Mounting

The instrument is designed for DIN-rail mounting. The mounting rail standard shipped with each instrument is used for wall mounting. Mount the DIN-rail to a wall and fasten the instrument with the sensor downwards and the display facing the front.

Attach the wires to the junction box according to the wiring diagram provided in the course of this section.

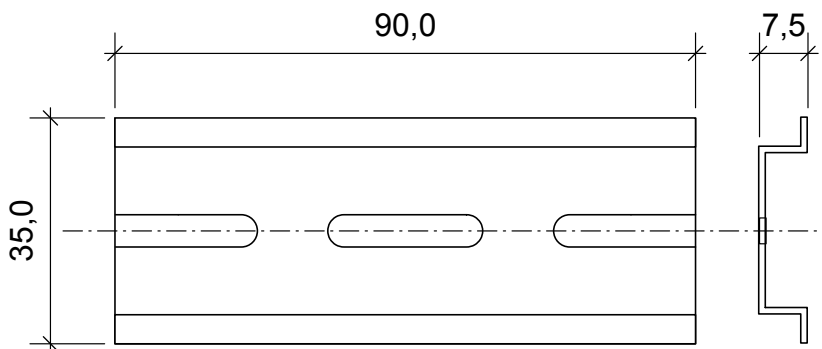

Mounting rail standard (P/N 9602.0050.10.03)

Installation and Start-Up - Section 2

For applications where wall mounting is not possible, an L-shaped mounting plate with DIN-rail is available as an option.

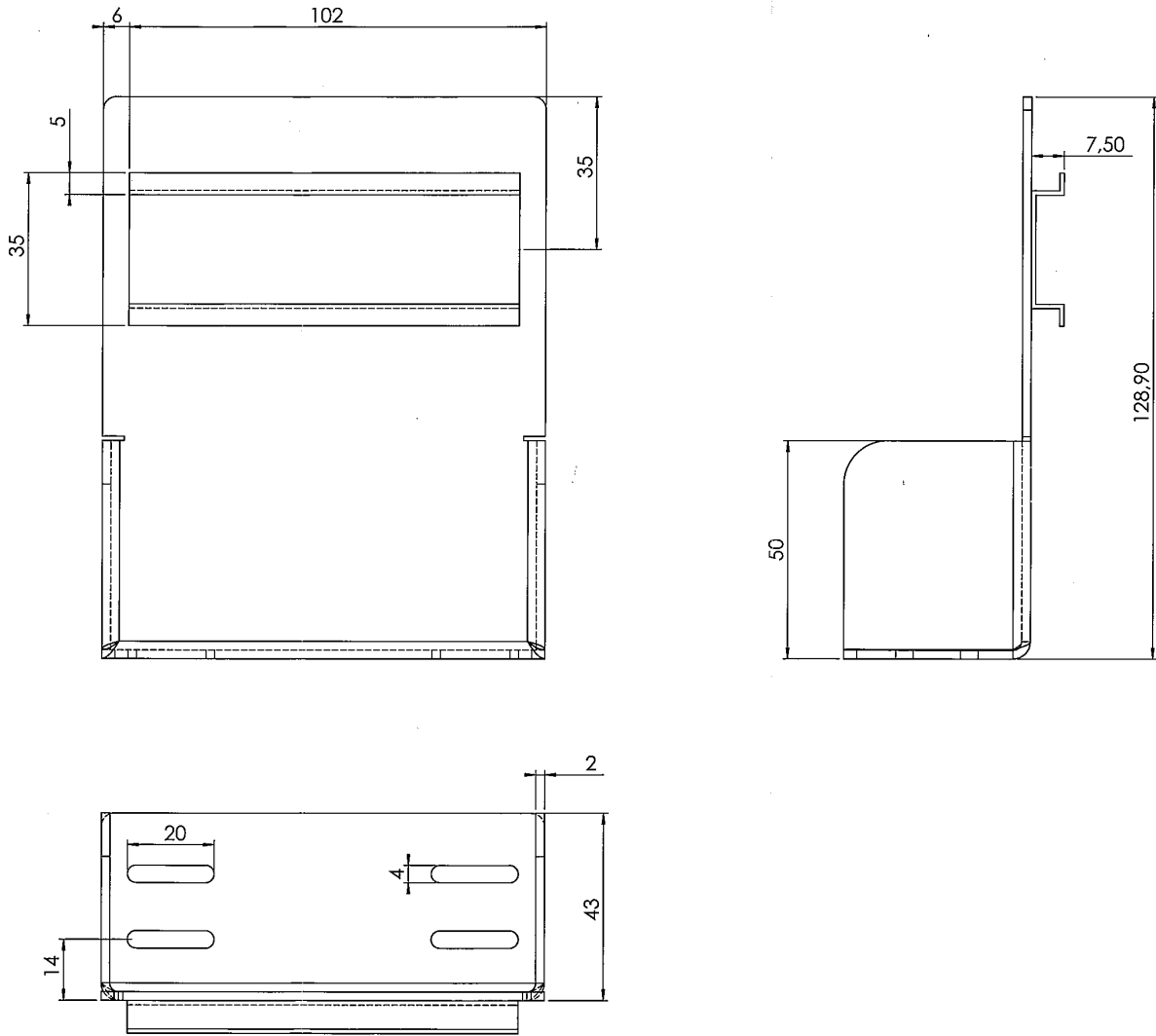

Optional L-shaped mounting plate with DIN-rail (P/N 9602.0051.10.02)

! Note:
Do not apply power until system is ready for start-up!

2.3 Duct Mounting

Observe the guidelines for installation of the instrument. For assembly and installation of the sensor extension see the schematics below and overleaf.

2.3.1 Connecting the Sensor Extension to the Instrument

1. Connect the Socket (A) to the plug in the sensor compartment located at the bottom of the Satellite XT. The groove of the Socket must face to the front.
2. Screw in the Internal Cap (B) and fasten it hand-tight.
3. Insert the Sensor Housing (C) with the nose of the Bayonet Catch facing to the front. Lock the Bayonet Catch with a quarter-turn right.

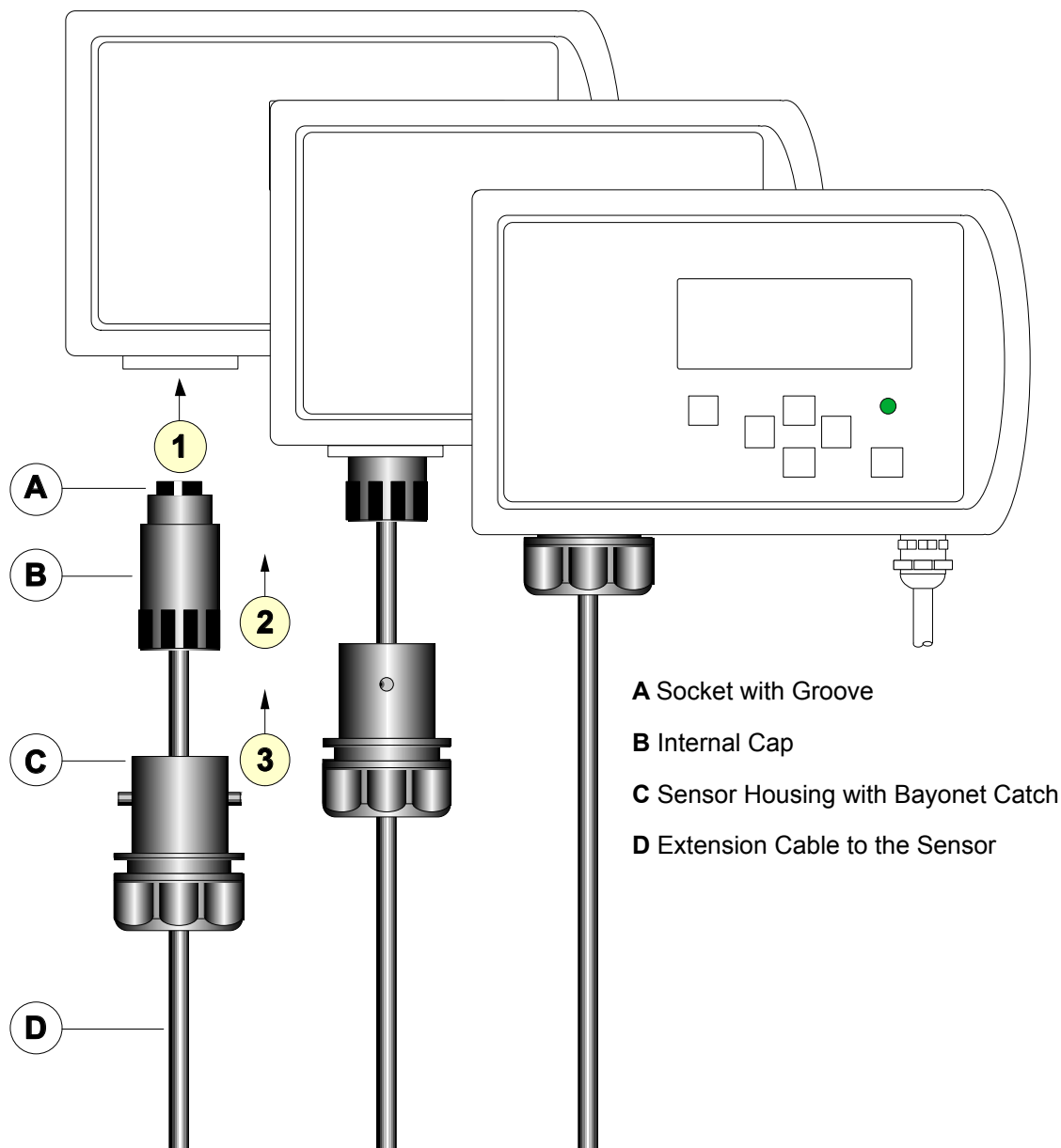

2.3.2 Mounting the Sensor Extension to the Duct

Duct

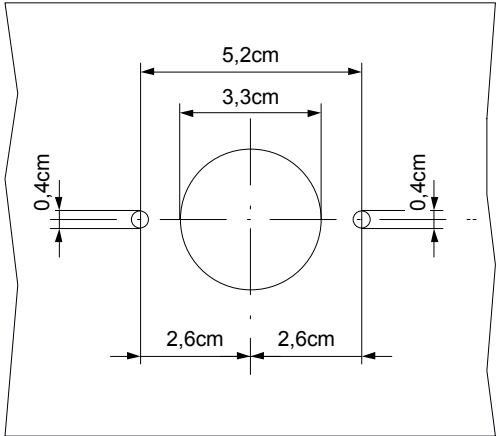

*) Duct Mounting Saddle Assembly various types available, see spare parts list, Section 8, Reference Information

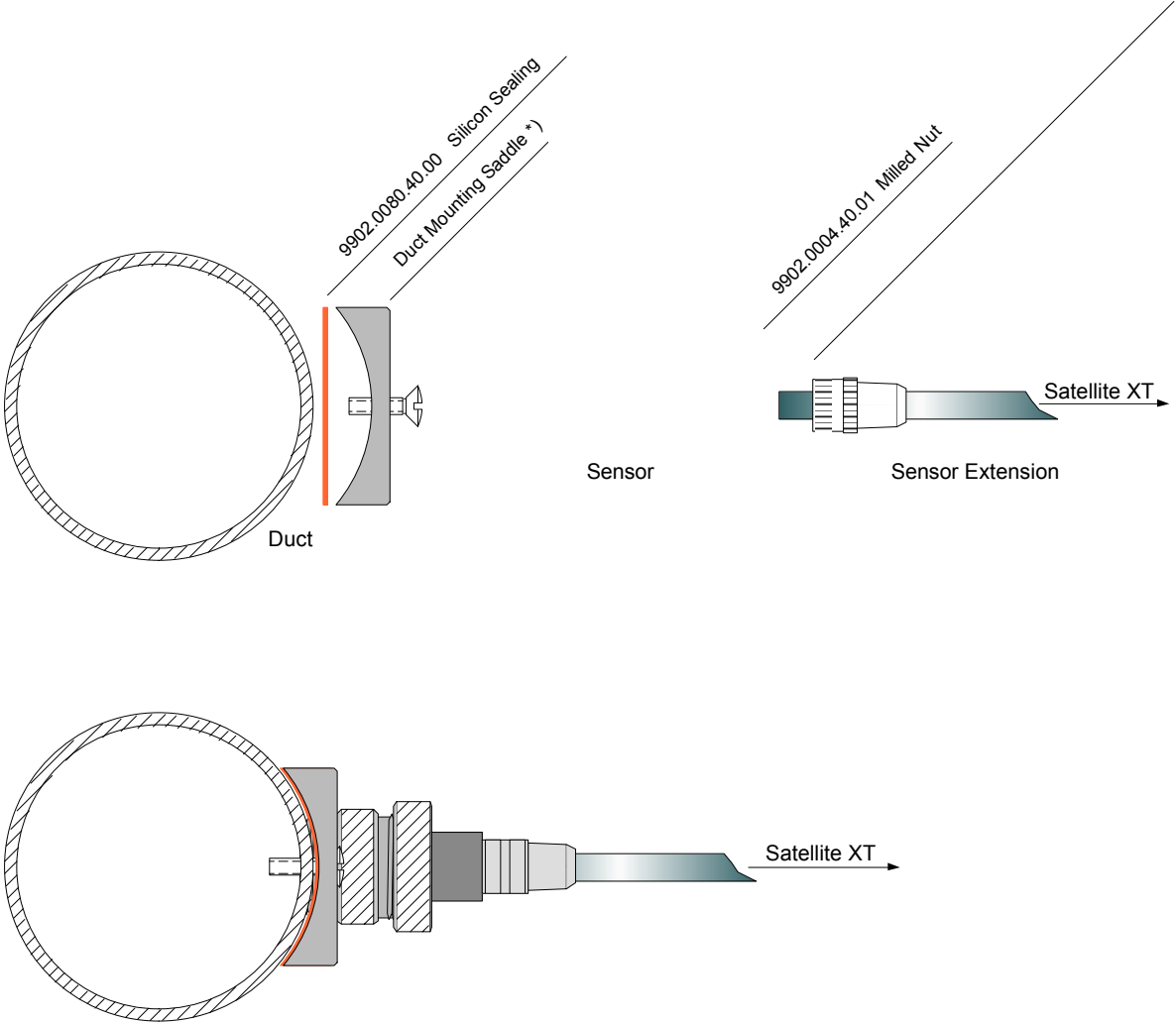

2.4 Wiring

There are two permanently attached cables extending from the bottom of the instrument, a 2-wire shielded cable with a length of 2 meters and a 6-wire shielded cable with a length of 3 meters.

The 2-wire shielded cable is required to power the instrument. The open end of the cable should be terminated in a junction box.

The 6-wire shielded cable provides a pair of connections for each of the 3 internal relays for activation of visual or audible external alarm devices.

Power Supply Connections		
P+	White	Power +
P-	Brown	Power -
S	Shield	cable shield

Relay Contacts		
1	White	Alarm 1 Relay
1	Brown	Alarm 1 Relay
2	Green	Alarm 2 Relay
2	Yellow	Alarm 2 Relay
3	Grey	Fault Relay
3	Pink	Fault Relay
S	Shield	Cable shield

Note:

All wiring for the Satellite XT and its related equipment must be in compliance with any local electrical and fire codes. The Satellite XT wiring must be kept away from any high power lines. All shielding for the wiring must be connected together and grounded at only one point in the system.

Installation and Start-Up - Section 2

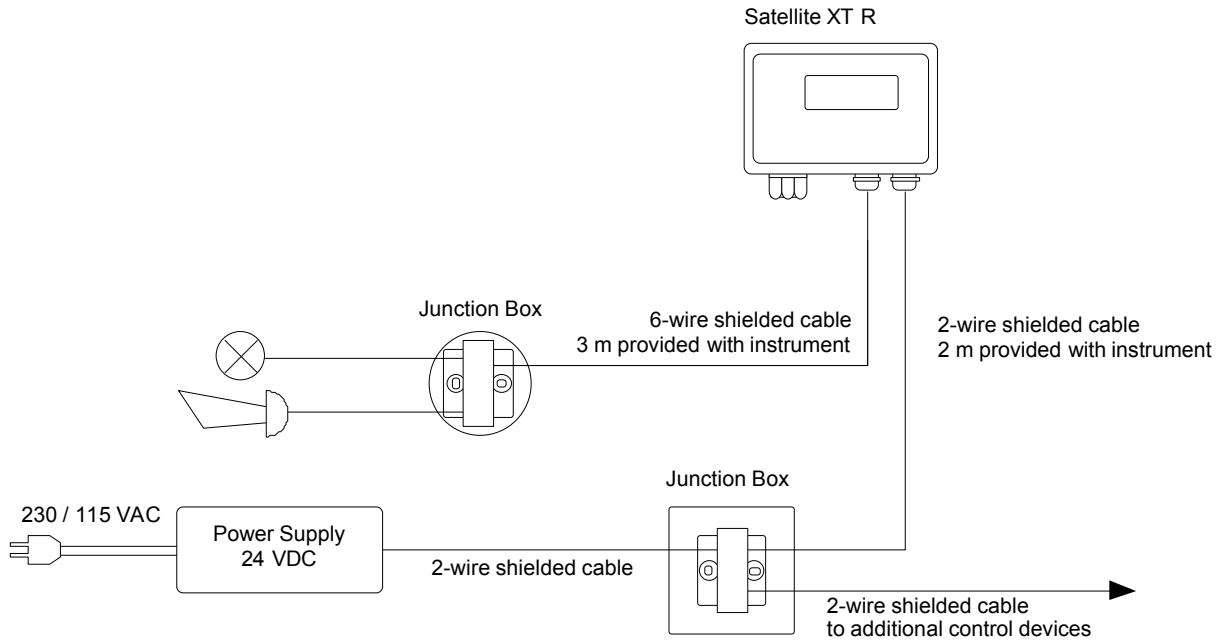

Wiring Diagram Satellite XT R - Basic Configuration

2.5 Initial Start-Up

When wiring is completed, a sensor must be assigned to each instrument. Every sensor is gas calibrated and these sensor specific calibration parameters are stored in its integrated data memory. Make sure to use only sensors designed for use with the Satellite XT.

Ex factory the instruments are shipped either unconfigured or already preconfigured according to the customer's specifications.

If the instruments are preconfigured, a certain sensor, which can be identified by its serial number printed on the packaging and the sensor label, is assigned and documented to one particular instrument. These data are stated in the test certificate provided with the shipment.

Switch on power supply. If no sensor is fitted, the display of the instrument shows the below message.



```

--- FAULT ---
NO SENSOR !

```

For applications without sensor extension open the bayonet catch of the sensor housing located on bottom of the instrument with a quarter-turn left and remove the sensor housing. For applications with sensor extension hold the plastic fitting at the duct side with two fingers and unscrew the metal fitting.

Take the assigned sensor out of the packaging. Remove shorting strap or wire link placed in the sensor plug before inserting it into the instrument. Not all sensors will feature this strap or link.

Caution: Failure to remove the shorting strap or wire link may result in damage to the Satellite.

For applications without sensor extension insert the sensor into the instrument's sensor compartment with the arrow printed on the sensor label facing upwards and to the front. Fit sensor housing by fastening the bayonet catch with a quarter-turn right.

For applications with sensor extension insert the sensor into the socket inside the metal fitting, properly aligning notch, groove, and arrow printed on the sensor label.

A sensor warm-up is performed and the graphic display shows the according screen until the displayed value is zero.

This does not apply for oxygen sensors. The warm-up time required depends on the type of sensor installed. The instrument is in the Maintenance Mode and the green LED is off.



```

SENSOR WARM-UP!
1 . 23 ppm

Satellite XT
AsH3
0 . 00 ppm

```

As soon as the displayed value reads zero, the instrument automatically switches to the Monitoring Mode. The graphic display shows the according screen, the green status LED is on, the instrument is monitoring.

! Note:

If the instrument does not perform as described above and a fault message is shown, please refer to Section 7, Troubleshooting.

! Instruments with OXYGEN sensors:

Span Adjustment must be performed prior to start-up. It is recommended to repeat Span Adjustment every 4 to 6 weeks. For details refer to Section 5, Calibration.

This section explains the different monitoring conditions and the Sub-Menus available under the Main Menu.

3.1 The Main Menu Screens

When the <esc> key is pressed, the instrument will leave the Monitoring Mode and go to the Main Menu. The instrument is now in the Maintenance Mode and the green LED is off.

Press the cursor keys <up> or <down> to move forwards and backwards in the Main Menu.

Press the <set> key to select a Sub-Menu. Press the <esc> key to go back to the Main Menu.

To return to the Monitoring Mode, go to the menu 'MONITORING' and press <set> to select. The display shows the monitoring screen again and the illuminated green LED indicates, that the instrument is in the Monitoring Mode.

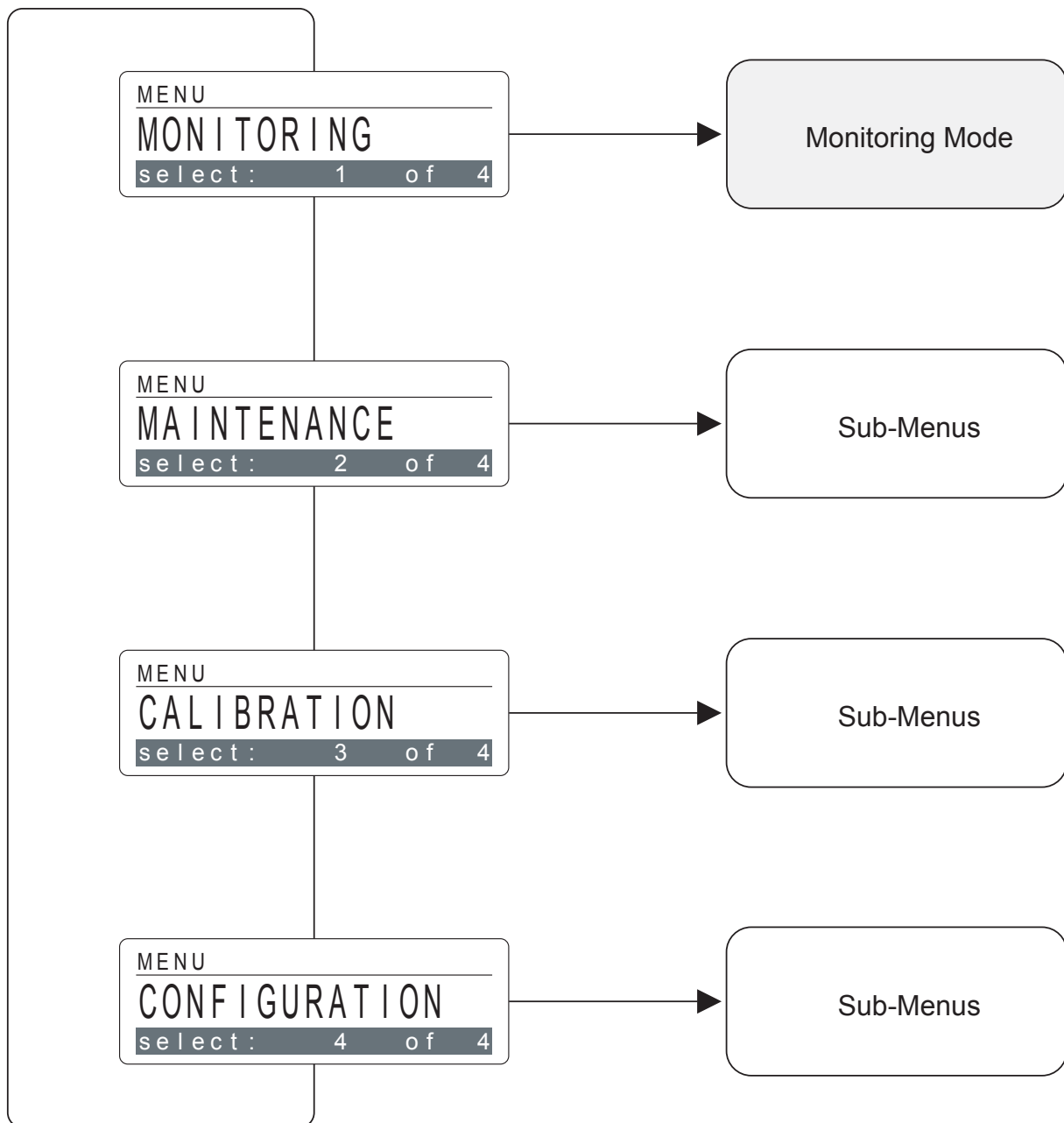



Main Menu - Monitoring

The instrument is in the operating mode Maintenance and the green LED is off. Press the cursor keys <up> or <down> to move forwards and backwards in the Main Menu. Press the <set> key to enter the Monitoring Mode.



<Normal Condition>

This screen and the illuminated green LED indicate that the instrument is in the Monitoring Mode and is operating properly.



<Alarm 1 Condition>

This screen shows that Alarm Level 1 has been exceeded and that there is an actual gas concentration of 0.07 ppm AsH3. (f.i. Alarm 1 set at 0.05 ppm AsH3)



<Alarm 2 Condition>

This screen shows that Alarm Level 2 has been exceeded and that there is an actual gas concentration of 0.12 ppm AsH3. (f.i. Alarm 2 set at 0.10 ppm AsH3)

MENU
 MAINTENANCE
 select: 2 of 4

Main Menu - Maintenance
 The instrument is in the Maintenance Mode and the green LED is off.
 Press the cursor keys <up> or <down> to move forwards and backwards in the Main Menu.
 To select a Sub-Menu, press the <set> key to enter.

Sub-Menus - Maintenance

MAINTENANCE
 SENSOR SERVICE
 select: 1 of 7

Sensor Service
 screen 1 of 7

MAINTENANCE
 ALARM RESET
 select: 2 of 7

Alarm Reset
 screen 2 of 7

MAINTENANCE
 ALARM/WARN TEST
 select: 3 of 7

Alarm/Warn Test
 screen 3 of 7

MAINTENANCE
 DEVICE INFOS
 select: 4 of 7

Device Infos
 screen 4 of 7

MAINTENANCE
 SENSOR INFOS
 select: 5 of 7

Sensor Infos
 screen 5 of 7

MAINTENANCE
 RESET DEVICE
 select: 6 of 7

Reset Device
 screen 6 of 7

MAINTENANCE
 SERVICE
 select: 7 of 7

Service
 screen 7 of 7

MENU
CALIBRATION
select: 3 of 4

CALIBRATION
GAS CALIBRATION
select: 1 of 2

CALIBRATION
MANUAL K-FACTOR
select: 2 of 2

Main Menu - Calibration

The instrument is in the Maintenance Mode and the green LED is off. Press the cursor keys <up> or <down> to move forwards and backwards in the Main Menu.

To select a Sub-Menu, press the <set> key to enter.

Sub menus - Calibration

**Gas Calibration
screen 1 of 2**

**Manual K-Factor
screen 2 of 2**



Main Menu - Configuration
The instrument is in the Maintenance Mode and the green LED is off.
Press the cursor keys <up> or <down> to move forwards and backwards in the Main Menu.
To select a Sub-Menu, press the <set> key to enter.

Sub Menus - Configuration



Alarm Settings
screen 1 of 10



Language
screen 2 of 10



Date Format
screen 3 of 10



Auto Selftest
screen 4 of 10

! This function is not available with instruments using oxygen sensors.



Security
screen 5 of 10



Password
screen 6 of 10

Continued

Main Menu - Configuration

Sub menus - Configuration

Location
screen 7 of 10

New Sensor Type
screen 8 of 10

Gas Name
screen 9 of 10

Relays
screen 10 of 10

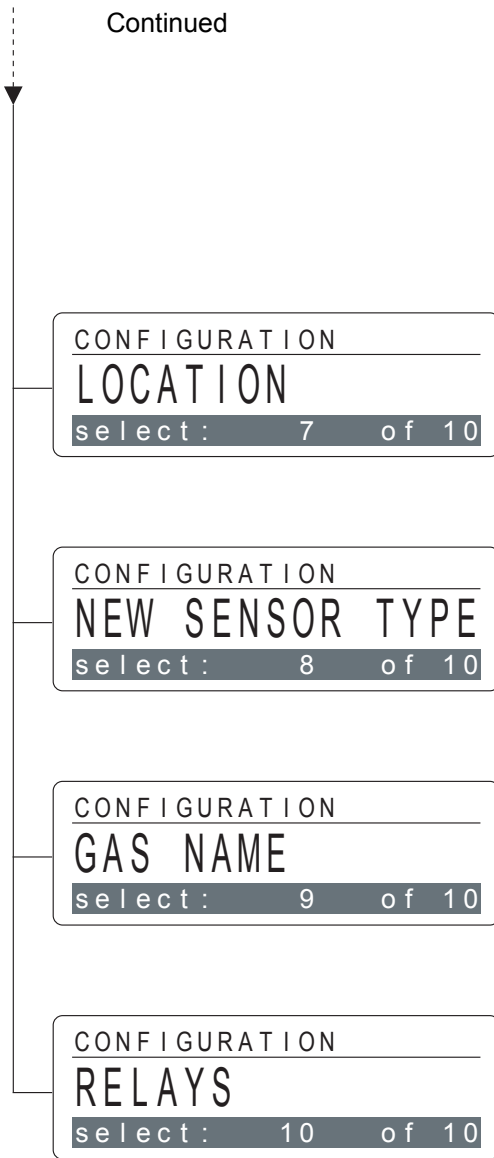

This section explains routine maintenance procedures including sensor replacement and specific information on sensor and instrument.



Main Menu - Maintenance

The instrument is in the Maintenance Mode and the green LED is off. Actuate the cursor keys <up> or <down> to move forwards and backwards in the Main Menu. To select a submenu, actuate the <set> key to enter.

Sub menus - Maintenance



Sensor Service
screen 1 of 7



Alarm Reset
screen 2 of 7



Alarm / Warn Test
screen 3 of 7



Device Infos
screen 4 of 7



Sensor Infos
screen 5 of 7



Continued

Main Menu - Maintenance

Continued

Submenus - Maintenance

Reset Device
screen 6 of 7



Service
screen 7 of 7



MAINTENANCE
SENSOR SERVICE
select: 1 of 7

Sensor Service
To perform a sensor replacement with a new sensor, which must have the same part number; see section 8 for Sensor Information. Use the <set> key to enter and follow the dialogue displayed at the bottom line of the screen. When the instrument has finished the sensor service procedure, it will automatically enter the Monitoring Mode.

SENSOR SERVICE
REMOVE SENSOR
<set> when ready

Remove Sensor
Remove the sensor presently installed and actuate the <set> key to proceed.

SENSOR SERVICE
REPLACEMENT
please insert !

Replacement
Insert the new sensor and actuate the <set> key to continue.

SENSOR SERVICE
LOAD NEW DATA ?
<set> to confirm

Load New Data ?
If you want the data of the new sensor to be loaded, confirm this by actuating the <set> key.

SENSOR SERVICE
LOADING DATA !
please wait !

Loading Data !
The new data are now loaded from the sensor into the instrument's internal memory.

SENSOR WARM-UP!
1 . 23 ppm

<Sensor Warm-Up Condition>
A sensor warm-up is performed and this screen is shown until the displayed value is zero.
This does not apply for oxygen sensors.
The warm-up time required depends on the type of sensor.

Satellite XT
AsH3
0 . 00 ppm

<Normal Monitoring Condition>
The instrument will automatically switch to the Monitoring Mode when the sensor service procedure is finished.

```
MAINTENANCE
ALARM RESET
select: 2 of 7
```

```
ALARM RESET
ALARMS OFF ?
<set> to confirm
```

Alarm Reset

Alarm Reset allows the user to reset the alarm indication of latched alarms. Use the <set> key to enter and follow the dialogue displayed at the bottom of the screen. Actuate the <esc> key to exit.

Alarms Off ?

Actuate the <set> key to confirm the reset of alarm indication with latching alarm. For non-latching alarms, alarm indication will be reset automatically.

```
MAINTENANCE
ALARM/WARN TEST
select: 3 of 7
```

```
ALARM/WARN TEST
SET ALARM 1 ?
select: 1 of 3
```

```
SET ALARM 1 ?
Alarm 1 set !
<esc> to exit !
```

Alarm/Warn Test

Used to verify the alarm function of any associated external device by simulating an Alarm 1, Alarm 2, and warning condition. Use the <set> key to select or use the cursor keys <up> and <down> to continue in the menu.

Set Alarm 1 ?

Allows the user to simulate an Alarm 1 condition. Actuate the <set> key to enter.

Alarm 1 set !

The Alarm 1 Relay is activated. Use the <esc> key to exit.

```
ALARM/WARN TEST
SET ALARM 2 ?
select: 2 of 3
```

```
SET ALARM 2 ?
Alarm 2 set !
<esc> to exit !
```

Set Alarm 2 ?

Allows the user to simulate an Alarm 2 condition. Actuate the <set> key to enter.

Alarm 2 set !

The Alarm 2 Relay is activated. Use the <esc> key to exit.



Continuación

Alarm/Warn Test

Continued

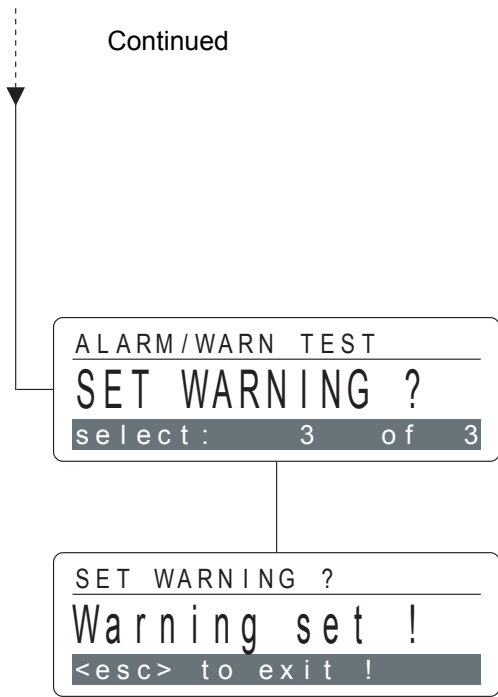

Set Warning ?

Allows the user to simulate a warning condition. Actuate the <set> key to enter.

Warning set !

The Fault Relay is activated, depending on the configuration. Use the <esc> key to exit.

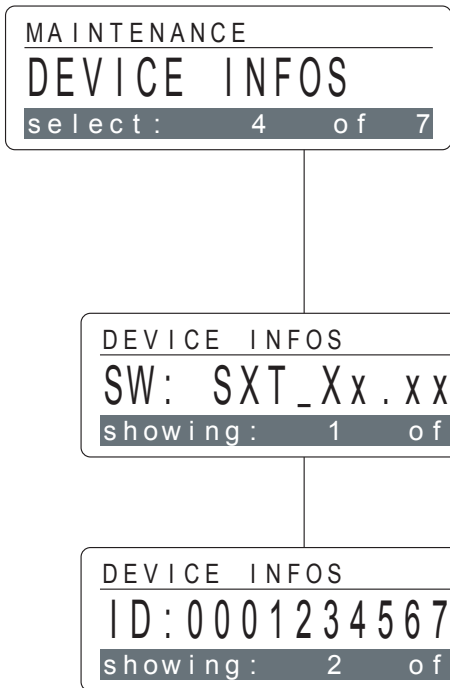

Device Infos

Used to obtain instrument specific information, i.e. software version and ID number. In general these informations are required for service purposes. Actuate the <set> key to select and move with the cursor keys <up> and <down>. Actuate the <esc> key to exit.

<Actual Software Version>

The version of the software presently installed is shown.

<Specific Identification Number>

The instrument's specific ID identification number is shown.

! Note:

Whenever a new sensor is installed, the K-factor will automatically revert to the default value 1.00. Any individual settings must be entered again; refer to section 5, Calibration.

```

MAINTENANCE
SENSOR INFOS
select: 5 of 7
    
```

Sensor Infos
 Provides specific information about the sensor presently installed, i.e. part number, serial number, date of first calibration, sensitivity, and revision number. These data are stored in the sensor's memory. Actuate the <set> key to select or use the cursor keys <up> and <down> to continue in the menu.

```

SENSOR INFOS
PART NUMBER
select: 1 of 5
    
```

Part number
 Actuate the <set> key to display the part number of the sensor presently installed.

```

PART NUMBER
9602-6000
<esc> to exit !
    
```

<Actual Sensor Part Number>
 Use this information to order replacement sensors. Additional order information is provided in Section 8, Sensor Order Information. Actuate <esc> to leave.

```

SENSOR INFOS
SERIAL NUMBER
select: 2 of 5
    
```

Serial Number
 Actuate the <set> key to display the serial number of the sensor presently installed.

```

SERIAL NUMBER
31
<esc> to exit !
    
```

<Actual Sensor Serial Number>
 This information may be required for service purposes. Actuate the <esc> key to leave.

```

SENSOR INFOS
1st CALIBRATION
select: 3 of 5
    
```

First Calibration
 Use the <set> key to display the date when the installed sensor was calibrated for the first time.

```

1st CALIBRATION
27.09.2006
<esc> to exit !
    
```

<Date of First Calibration>
 This information may be required for service purposes and to check the age of the sensor. Actuate <esc> to leave.

Continued

Sensor Infos

Continued

```
SENSOR INFOS  
SENSITIVITY  
select: 4 of 5
```

Sensitivity

Use the <set> key to display the sensor sensitivity determined during the first calibration.

```
SENSITIVITY  
123 nA/ppm  
<esc> to exit !
```

<Actual Sensitivity>

This information may be required for service purposes. Actuate the <esc> key to leave.

```
SENSOR INFOS  
REVISION NUMBER  
select: 5 of 5
```

Revision Number

Use the <set> key to display the revision number of the gas related information stored in the sensor's memory..

```
REVISION NUMBER  
0  
<esc> to exit !
```

<Actual Revision Number>

This information may be required for service purposes. Actuate the <esc> key to leave.

```
MAINTENANCE
-----
RESET DEVICE
select: 6 of 7
```

Reset Device
Offers the possibility to perform a “warm start” of the instrument.
Actuate the <set> key to select.

```
RESET DEVICE
-----
ARE YOU SURE ?
<esc> to exit !
```

Are You Sure ?
This screen is to confirm that a software reset should be performed. Actuate the <set> key to confirm or use the <esc> key to exit.

```
SENSOR WARM-UP!
  1 . 23 ppm
```

<Sensor Warm-Up Condition>
A sensor warm-up is performed and this screen is shown until the displayed value is zero, except for Oxygen sensors.
The warm-up time depends on the type of sensor.

```
Satellite XT
AsH3
  0 . 00 ppm
```

<Normal Monitoring Condition>
The instrument will automatically switch to the Monitoring Mode when the sensor service procedure is finished.

```
MAINTENANCE
-----
SERVICE
select: 7 of 7
```

Service
This submenu is used exclusively by trained Service Personnel.
The functions are password protected.

```
SERVICE
-----
PASSWORD: ***
please enter !
```

This section describes calibration procedures for the Satellite XT. Calibration can be performed either automatically using a dynamic gas calibration or manually by entering a calculated correction factor called K-factor.

Main Menu - Calibration

The instrument is in the Maintenance Mode and the green LED is off. Actuate the cursor keys <up> or <down> to move forwards and backwards in the Main Menu. To select a submenu, actuate the <set> key to enter.



Sub menus - Calibration

**Gas Calibration
screen 1 of 2**



**Manual K-Factor
screen 2 of 2**



!Note:

If a high degree of accuracy in monitoring is required, monthly calibration with calibration gas of a known concentration is recommended.

When performing a dynamic calibration, a new correction factor (K-factor) is calculated automatically. The actual value can be displayed in the submenu Manual K-Factor.

Use appropriate safety precautions when handling toxic or corrosive gases and properly vent, if possible.

! Instruments with OXYGEN sensors:

Span Adjustment must be performed prior to start-up. It is recommended to repeat Span Adjustment every 4 to 6 weeks. For details refer to Section 5, Calibration.

CALIBRATION
GAS CALIBRATION
select: 1 of 2

Gas Calibration

The gas calibration submenu is used for dynamic calibration. For zero adjustment use clean or synthetic air free from measuring gas or any other interfering gases. The sensor must be warmed-up before calibration. For span adjustment it is recommended to use test gas of a known concentration at or slightly above the TLV for the target gas.

Always keep to the correct sequence, first perform zero adjustment, then Span Adjustment.

GAS CALIBRATION
ZERO ADJUST
select: 1 of 2

Zero Adjust

Zero adjustment applies for all sensors except oxygen sensors.

Use the <set> key to enter and follow the dialogue displayed.

ZERO ADJUST
APPLY AIR !
use clean air !

Apply Air !

Apply clean or synthetic air to the sensor and actuate the <set> key to continue.

ZERO ADJUST
0.01 ppm
Value stable ?

<Actual Zero Point>

Allow the zero reading to stabilize. If the reading is already zero, zero adjustment is not necessary. Actuate the <esc> key to exit. If the reading is not zero, actuate the <set> key to re-adjust the zero point and to continue the procedure.

ZERO ADJUST
0.00 ppm
Value o.k. ?

<Re-adjusted Zero Point>

The reading is zero. Actuate the <set> key to proceed.

ZERO ADJUST
SAVE ?
<set> to confirm

Save ?

Actuate the <set> key to save the new zero point and store it in the unit's internal memory.

Continued

Gas Calibration (Calibración de gas)

Continued

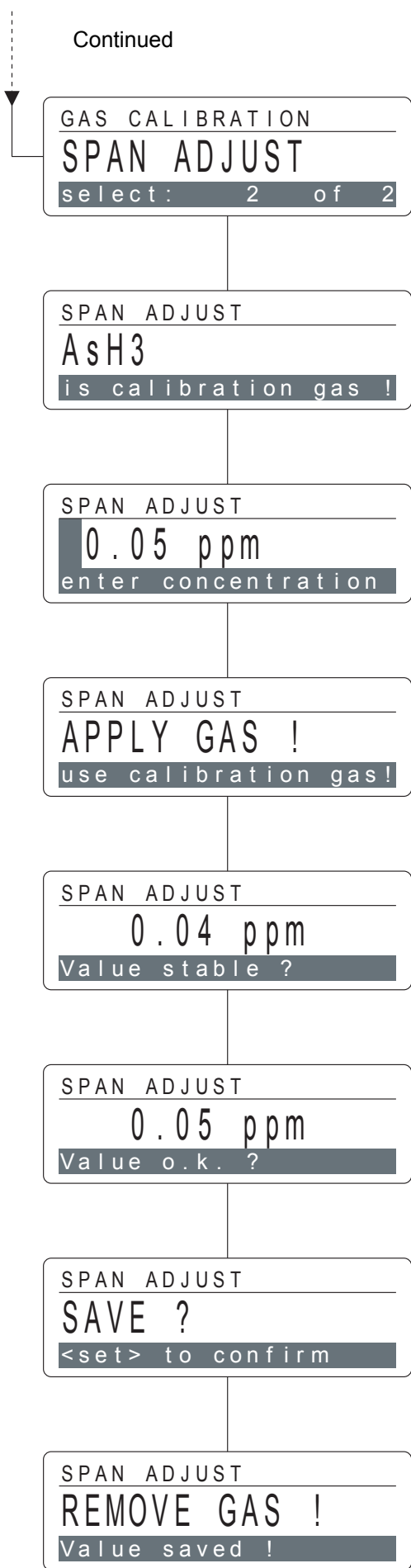

Span Adjust

Span adjustment applies for all sensors, including oxygen sensors. Use the <set> key to enter and follow the dialogue displayed.

<Actual Calibration Gas>

The instrument shows which calibration gas is required for the actual sensor type.

<Actual Concentration for Calibration>

The recommended concentration for span adjustment is displayed. Default value is TLV concentration for the target gas. When using calibration gas of a different concentration, change the value accordingly. After the new value has been entered, actuate the <set> key to continue.

Apply Gas !

Place the calibration cap over the sensor and start the calibration gas flow (18 l/h or 300 ccm/min). Actuate the <set> key to continue.

<Actual Span Value>

Allow the reading to stabilize. If the reading matches the concentration of the calibration gas, span adjustment is not necessary. Actuate the <esc> key to exit. If the reading does not match the concentration of the calibration gas, actuate the <set> key to re-adjust the span value and to continue the procedure.

<Re-adjusted Span Value>

The reading matches the concentration of the calibration gas. Actuate the <set> key to proceed.

Save ?

Actuate the <set> key to save the new span value and store it in the unit's internal memory.

Remove Gas !

Stop the calibration gas flow. Remove gas and calibration cap. Allow several minutes for the sensor to clear.

```

CALIBRATION
MANUAL K - FACTOR
select: 2 of 2
    
```

```

MANUAL K - FACTOR
1.00
please enter !
    
```

Manual K-Factor

This submenu is used to manually calibrate the instrument by entering a new K-factor. This factor is a multiplication or correction value used to calibrate the response of the instrument to a specific gas concentration. The factory default K-Factor for all gases is 1.00. Use the <set> key to enter. The instrument will display the actual Kfactor.

< Actual K-Factor >

Use the cursor keys <left> or <right> to reach the desired position. Use the cursor keys <up> and <down> to select the figures you wish to enter. The K-factor must be in the range of 0.20 and 5.00. After a new value has been entered, actuate the <set> key to confirm or <esc> to exit.

! Note:

Individual settings for the manual K-factor will automatically revert to the default value 1.00, whenever the sensor is replaced by a new sensor.

This section describes the instrument's default configuration and procedures how to adapt it to individual requirements.



Main Menu - Configuration

The instrument is in the Maintenance Mode and the green LED is off.

Press the cursor keys <up> or <down> to move forwards and backwards in the Main Menu.

To select a Sub-Menu, press the <set> key to enter.

Sub menus - Configuration



Alarm Settings
screen 1 of 10

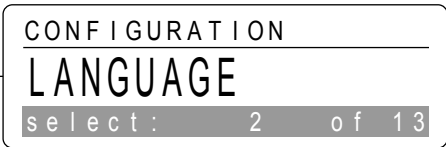

Language
screen 2 of 10



Date Format
screen 3 of 10



Auto Selftest
screen 4 of 10



Security
screen 5 of 10

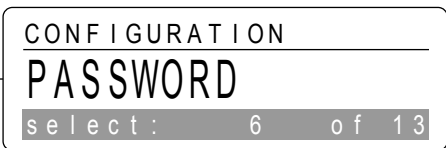

Continued

Main Menu - Configuration

Sub menus - Configuration

Password
screen 6 of 10

Location (Ubicación)
screen 7 of 10

New Sensor Type
screen 8 of 10

Gas Name
screen 9 of 10

Relays
screen 10 of 10

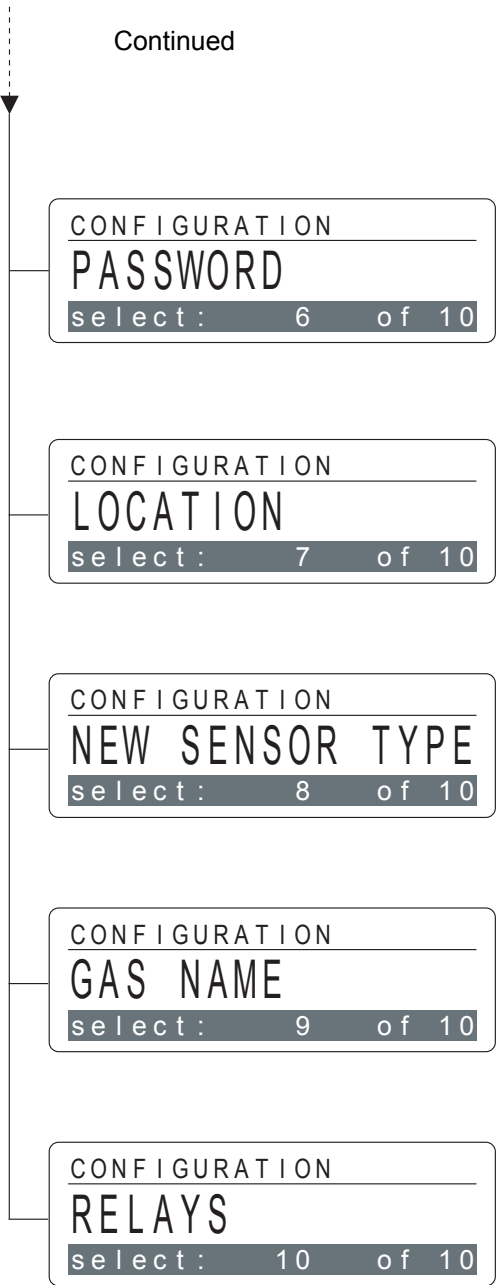

! Note:
Individual settings for alarm levels and gas name will automatically revert to the factory programmed settings, whenever a new sensor type with a part number different from the part number of the sensor used before is installed.

```

CONFIGURATION
ALARM SETTINGS
select: 1 of 10
    
```

Alarm Settings

Allows the user to enter or change various settings for Alarm 1 and Alarm 2 activation.
Use the <set> key to enter.

```

ALARM SETTINGS
ALARM 1
select: 1 of 2
    
```

Alarm 1

For Alarm 1 settings, use the <set> key to enter or continue in the menu with the cursor keys <up> or <down>.

```

ALARM SETTINGS
ALARM 2
select: 2 of 2
    
```

Alarm 2

For Alarm 2 settings, use the <set> key to enter or continue in the menu with the cursor keys <up> or <down>.

ALARM SETTINGS
ALARM 1
select: 1 of 2

Alarm 1
Allows the user to configure all parameters for Alarm 1 (lower alarm level) activation.

ALARM 1
ALARM 1 STATE
select: 1 of 4

Alarm 1 state
Used to enable / disable the Alarm 1 activation.

ALARM 1
ALARM 1 LEVEL
select: 2 of 4

Alarm 1 Level
Used to set individual alarm levels for Alarm 1 activation.

ALARM 1
ALARM 1 TRIGGER
select: 3 of 4

Alarm 1 Trigger
Used to define the trigger condition for Alarm 1 activation.

ALARM 1
ALARM 1 LATCH
select: 4 of 4

Alarm 1 Latch
Used to define the Alarm 1 activation to be latching or non-latching.

ALARM 1
 ALARM 1 STATE
 select: 1 of 4

Alarm 1 State
 Used to enable / disable the Alarm 1 activation. Default setting is enabled. Use the <set> key to enter. The instrument will show the actual setting.

ALARM 1 STATE
 DISABLED
 select: 1 of 2

Disabled
 Allows the user to turn off the Alarm 1 activation. Press the cursor keys <up> or <down> to change. Press the <set> key to confirm or <esc> to exit.

ALARM 1 STATE
 ENABLED
 select: 2 of 2

Enabled
 Allows the user to turn on the Alarm 1 activation. Press the cursor keys <up> or <down> to change. Press the <set> key to confirm or <esc> to exit.

ALARM 1
 ALARM 1 LEVEL
 select: 2 of 4

Alarm 1 Level
 Used to set individual alarm levels for Alarm 1 activation. Default setting is 1 x TLV (Threshold Limit Value) for the target gas. Press the <set> key to enter and show the actual setting.

ALARM 1 LEVEL
 0.05 ppm
 please enter !

<Actual Alarm 1 Level>
 To change the value, use the cursor keys <left> or <right> to reach the desired position. Use the cursor keys <up> and <down> to select the figures you wish to enter. After the new value has been entered, press the <set> key to confirm or <esc> to exit.

```
ALARM 1
ALARM 1 TRIGGER
select: 3 of 4
```

```
ALARM 1 TRIGGER
GREATER THAN
select: 1 of 2
```

```
ALARM 1 TRIGGER
LESS THAN
select: 2 of 2
```

Alarm 1 Trigger

Used to define the trigger condition for Alarm 1 activation. Default setting is Greater Than. Use the <set> key to enter. The instrument will show the actual setting.

Greater Than

Defines that an Alarm 1 condition will be indicated when the actual gas concentration exceeds the preset level for Alarm 1.

Press the cursor keys <up> or <down> to change. Press the <set> key to confirm or <esc> to exit..

Less Than

Defines that an Alarm 1 condition will be indicated when the actual gas concentration falls below the preset level for Alarm 1.

Press the cursor keys <up> or <down> to change. Press the <set> key to confirm or <esc> to exit..

```
ALARM 1
ALARM 1 LATCH
select: 4 of 4
```

```
ALARM 1 LATCH
DISABLED
select: 1 of 2
```

```
ALARM 1 LATCH
ENABLED
select: 2 of 2
```

Alarm 1 Latch

Used to define the Alarm 1 activation to be latching or non-latching. Default setting is enabled. Use the <set> key to enter. The instrument will show the actual setting.

When enabled, alarm reset must be done manually. Non-latching alarms will be reset automatically, upon correction of the alarm condition.

Disabled

Defines the Alarm 1 activation to be non-latching. Press the cursor keys <up> or <down> to change. Press the <set> key to confirm or <esc> to exit.

Enabled

Defines the Alarm 1 activation to be latching. Press the cursor keys <up> or <down> to change. Press the <set> key to confirm or <esc> to exit.

ALARM SETTINGS
ALARM 2
select: 2 of 2

Alarm 2
Allows the user to configure all parameters for Alarm 2 (upper alarm level) activation.
For all subsequent Alarm 2 settings, please follow the procedures described in the corresponding section for Alarm 1 settings.

ALARM 2
ALARM 2 STATE
select: 1 of 4

Alarm 2 State
Used to enable / disable the Alarm 2 activation.

ALARM 2
ALARM 2 LEVEL
select: 2 of 4

Alarm 2 Level
Used to set individual alarm levels for Alarm 2 activation.

ALARM 2
ALARM 2 TRIGGER
select: 3 of 4

Alarm 2 Trigger
Used to define the trigger condition for Alarm 2 activation.

ALARM 2
ALARM 2 LATCH
select: 4 of 4

Alarm 2 Latch
Used to define the Alarm 2 activation to be latching or non-latching.

```

CONFIGURATION
LANGUAGE
select: 2 of 10
    
```

Language

Used to select the desired language for menu operation. Default setting is English. Use the <set> key to enter. The instrument will display the actual language.

```

LANGUAGE
GERMAN
select: 1 of 2
    
```

German

Press the cursor keys <up> or <down> to change. Press the <set> key to confirm or <esc> to exit.

```

LANGUAGE
ENGLISH
select: 2 of 2
    
```

English

Press the cursor keys <up> or <down> to change. Press the <set> key to confirm or <esc> to exit.

```

CONFIGURATION
DATE FORMAT
select: 3 of 10
    
```

Date Format

Used to define the format how to display the date (only used in the Sub-Menu Sensor Infos, Date of First Calibration). Default setting is International. Use the <set> key to enter. The actual date format is displayed.

```

DATE FORMAT
INTERNATIONAL
select: 1 of 2
    
```

International

International date format is DD.MM.YYYY. Press the cursor keys <up> or <down> to change. Press the <set> key to confirm or <esc> to exit.

```

DATE FORMAT
USA
select: 2 of 2
    
```

USA

USA date format is MM-DD-YYYY. Press the cursor keys <up> or <down> to change. Press the <set> key to confirm or <esc> to exit.

```

CONFIGURATION
-----
AUTO SELFTEST
select: 4 of 10
    
```

```

AUTO SELFTEST
-----
DISABLED
select: 1 of 2
    
```

```

AUTO SELFTEST
-----
ENABLED
select: 2 of 2
    
```

Auto Selftest

The instrument's self-diagnostics provides an on-line preventive sensor selftest performed automatically every 24 hours, which may be enabled or disabled. Default setting is enabled.

Use the <set> key to enter. The display will show the actual setting.

!The Auto Selftest function is not applicable for Oxygen sensors.

Disabled

Allows the user to turn off the Auto Selftest. Press the cursor keys <up> or <down> to change. Press the <set> key to confirm or <esc> to exit.

Enabled

Allows the user to turn on the Auto Selftest. Press the cursor keys <up> or <down> to change. Press the <set> key to confirm or <esc> to exit.

```

CONFIGURATION
-----
SECURITY
select: 5 of 10
    
```

```

SECURITY
-----
PASSWORD ON
select: 1 of 2
    
```

```

SECURITY
-----
PASSWORD OFF
select: 2 of 2
    
```

Security

Exiting the Monitoring Mode and entering the Maintenance Mode, may be password protected, to prevent the instrument from manipulations by unauthorized personnel.

Ex factory the password protection is disabled.

Use the <set> key to enter. The instruments shows the actual setting.

Password On

Allows the user to enable the password protection. Press the cursor keys <up> or <down> to change. Press the <set> key to confirm or <esc> to exit.

Password Off

Allows the user to disable the password protection. Press the cursor keys <up> or <down> to change. Press the <set> key to confirm or <esc> to exit..

CONFIGURATION
PASSWORD
 select: 6 of 10

Password

Allows the user to enter or change the password.
 Ex factory the password is <000>.
 Use the <set> key to enter. The instrument will display the actual password.

PASSWORD
 000
 please enter !

<Actual Password>

To change the password, use the cursor keys <left> or <right> to reach the desired position. Use the cursor keys <up> and <down> to select the figures you wish to enter. After the new password has been entered, press the <set> key to confirm or <esc> to exit.

CONFIGURATION
LOCATION
 select: 7 of 10

Location

Allows the user to enter a description defining the monitoring point. Ex factory it reads <Satellite XT>. Up to 13 alphanumeric characters can be entered.
 Use the <set> key to enter. The instrument will display the actual location.

LOCATION
 Gas Cabinet
 please enter !

<Actual Location>

Use the cursor keys <left> or <right> to reach the desired position. Use the cursor keys <up> and <down> to select the characters you wish to enter. When the new location has been entered completely, press the <set> key to confirm or <esc> to exit.

```

CONFIGURATION
NEW SENSOR TYPE
select: 8 of 10
    
```

New Sensor Type
 Allows the user to configure the instrument for a new sensor type with a part number, which is different from the one presently used. See Section 8 for Sensor Information.
 Press the <set> key to enter and follow the dialogue displayed.

```

NEW SENSOR TYPE
REMOVE SENSOR
<set> when ready
    
```

Remove Sensor
 Remove the sensor presently installed and press the <set> key to proceed.

```

NEW SENSOR TYPE
NEW SENSOR
please insert !
    
```

Load New Data ?
 If you want the data of the new sensor to be loaded, confirm this by pressing the <set> key.

```

NEW SENSOR TYPE
LOAD NEW DATA ?
<set> to confirm
    
```

Loading Data !
 The instrument is now loading the new data from the sensor into the unit's internal memory.

```

NEW SENSOR TYPE
LOADING DATA !
please wait !
    
```

```

CONFIGURATION
GAS NAME
select: 9 of 10
    
```

Gas Name
 Allows the user to enter a different gas name than the one stored in the sensor's data memory. Up to 7 alpha-numeric characters can be entered. Use the <set> key to enter. The instrument will display the actual gas name.

```

GAS NAME
AsH3
please enter !
    
```

<Actual Gas Name>
 Use the cursor keys <left> or <right> to reach the desired position. Use the cursor keys <up> and <down> to select the characters you wish to enter. When the new gas name has been entered completely, press the <set> key to confirm or <esc> to exit.

```

CONFIGURATION
RELAYS
select: 10 of 10
    
```

Relays
 Allows the user to enter or change various settings for the internal relay contacts for Alarm 1, Alarm 2, and Fault.
 Use the <set> key to enter.

```

RELAYS
RELAY STATE
select: 1 of 3
    
```

Relay State
 Used to individually define the relays to be either deenergized (normally open contact) or energized (normally closed contact).
 Use the <set> key to enter or continue in the menu with the cursor keys <up> or <down>.

```

RELAYS
ALARM DELAY
select: 2 of 3
    
```

Alarm Delay
 Used to set a delay for the relay activation in case of concentration alarms.
 Use the <set> key to enter or continue in the menu with the cursor keys <up> or <down>.

```

RELAYS
FAULT TRIGGER
select: 3 of 3
    
```

Fault Trigger
 Used to define the trigger conditions for activation of the Fault Relay.
 Use the <set> key to enter or continue in the menu with the cursor keys <up> or <down>.

```

RELAYS
-----
RELAY STATE
select: 1 of 3
    
```

Relay State
 Used to individually define the Alarm 1, Alarm 2, and Fault Relay to be either deenergized (normally open contact) or energized (normally closed contact). Ex factory the relays are deenergized (normally open contacts).
 Use the <set> key to enter.

```

RELAY STATE
-----
ALARM 1 RELAY
select: 1 of 3
    
```

Alarm 1 Relay
 Allows to set the Alarm 1 Relay state.

```

RELAY STATE
-----
ALARM 2 RELAY
select: 2 of 3
    
```

Alarm 2 Relay
 Allows to set the Alarm 2 Relay state.

```

RELAY STATE
-----
FAULT RELAY
select: 3 of 3
    
```

Fault Relay
 Allows to set the Fault Relay state.

```

RELAY STATE
-----
ALARM 1 RELAY
select: 1 of 3
    
```

Alarm 1 Relay
 Allows the user to set the Alarm 1 Relay state.
 Use the <set> key to enter.
 The instrument will show the actual setting.

```

ALARM 1 RELAY
-----
DEENERGIZED/NO
select: 1 of 2
    
```

Deenergized / NO
 Defines the Alarm 1 Relay to be deenergized (normally open contact).
 Press the cursor keys <up> or <down> to change.
 Press the <set> key to confirm or <esc> to exit.

```

ALARM 1 RELAY
-----
ENERGIZED/NC
select: 2 of 2
    
```

Energized / NC
 Defines the Alarm 1 Relay to be energized (normally closed contact).
 Press the cursor keys <up> or <down> to change.
 Press the <set> key to confirm or <esc> to exit.

```

RELAY STATE
ALARM 2 RELAY
select: 2 of 3
    
```

Alarm 2 Relay

Allows the user to set the Alarm 2 Relay state.
Use the <set> key to enter.
The instrument will show the actual setting.

```

ALARM 2 RELAY
DEENERGIZED/NO
select: 1 of 2
    
```

Deenergized / NO

Defines the Alarm 2 Relay to be deenergized (normally open contact).
Press the cursor keys <up> or <down> to change.
Press the <set> key to confirm or <esc> to exit.

```

ALARM 2 RELAY
ENERGIZED/NC
select: 2 of 2
    
```

Energized / NC

Defines the Alarm 2 Relay to be energized (normally closed contact).
Press the cursor keys <up> or <down> to change.
Press the <set> key to confirm or <esc> to exit.

```

RELAY STATE
FAULT RELAY
select: 3 of 3
    
```

Fault Relay

Allows the user to set the Fault Relay state.
Use the <set> key to enter.
The instrument will show the actual setting.

```

FAULT RELAY
DEENERGIZED/NO
select: 1 of 2
    
```

Deenergized / NO

Defines the Fault Relay to be deenergized (normally open contact).
Press the cursor keys <up> or <down> to change.
Press the <set> key to confirm or <esc> to exit.

```

FAULT RELAY
ENERGIZED/NC
select: 2 of 2
    
```

Energized / NC

Defines the Fault Relay to be energized (normally closed contact).
Press the cursor keys <up> or <down> to change.
Press the <set> key to confirm or <esc> to exit.

```
RELAYS
ALARM DELAY
select: 2 of 3
```

```
ALARM DELAY
3.0 sec.
please enter !
```

Alarm Delay

Used to define an alarm delay for concentration alarms. Minimum value is 0, maximum setting is 99.9 seconds. Default setting is 3.0 seconds. Press the <set> key to enter and show the actual setting.

<Actual Alarm Delay>

To change the value, use the cursor keys <left> or <right> to reach the desired position. Use the cursor keys <up> and <down> to select the figures you wish to enter. After the new value has been entered, press the <set> key to confirm or <esc> to exit.

```
RELAYS
FAULT TRIGGER
select: 3 of 3
```

```
FAULT TRIGGER
FAULT ONLY
select: 1 of 4
```

```
FAULT TRIGGER
FAULT+WARNING
select: 2 of 4
```

```
FAULT TRIGGER
FAULT+MAINT
select: 3 of 4
```

```
FAULT TRIGGER
ALL
select: 4 of 4
```

Fault Trigger

Allows the user to define, which fault conditions will activate the Fault Relay. Ex factory the setting is Fault Only. Use the <set> key to enter. The instrument will show the actual setting.

Fault Only

Used to configure the Fault Relay to be activated in case of a fault condition only. Press the cursor keys <up> or <down> to change. Press the <set> key to confirm or <esc> to exit.

Fault + Warning

Used to configure the Fault Relay to be activated in case of a fault or warning condition only. Press the cursor keys <up> or <down> to change. Press the <set> key to confirm or <esc> to exit.

Fault + Maintenance

Used to configure the Fault Relay to be activated in case of a fault or maintenance condition only. Press the cursor keys <up> or <down> to change. Press the <set> key to confirm or <esc> to exit.

All

Used to configure the Fault Relay to be activated in case of a fault, warning, or maintenance condition. Press the cursor keys <up> or <down> to change. Press the <set> key to confirm or <esc> to exit.

This section will help to determine the source of a fault or warning condition and will provide a corrective action.

7.1 Warning and Fault Messages

There are two general indications, warnings and faults, which require different attention. If a fault or warning message does not appear in this section or if further assistance is required, contact your MST Service Department.

7.1.1 Warnings

A warning condition indicates that the instrument requires some attention, but the instrument is still able to monitor and operate as programmed.

The following will occur when the instrument detects a warning condition:

- the green status LED is flashing
- depending on the configuration, the fault relay will be activated

Press the <set> key to acknowledge and reset a Warning Condition.



Low Zero !

This message indicates that the zero point of the sensor is out of the optimum range.

To correct this problem, check the zero adjustment and recalibrate, if necessary.



Check Sensor !

This message indicates that the sensor sensitivity does not comply with the specifications.

The sensor must soon be replaced.

Whilst most sensors will work for another 2-6 weeks, there are circumstances that may cause an earlier failure of the sensor cell. Honeywell therefore suggests that customers with more critical needs carry out the replacement of the sensor cell within 3 days (72 hours) of receiving the “check sensor” message.

To receive this message, the function Auto Selftest must be enabled; refer to Section 6, Configuration.

! This function is not available for instruments with oxygen sensor.

7.1.2 Faults

Instrument faults refer to a problem which prevents the instrument from operating properly and interferes with the ability to monitor or document concentration alarms.

If the instrument has detected an instrument fault, the green status LED is off and the fault relay is activated. The LCD display is flashing while indicating the specific fault message.

---- FAULT ----
ADC NOT READY !

Fault - ADC Not Ready !

This indicates that there is a problem with the internal electronics. The AD Converter has failed. Switch power supply for this unit off and on again. If the instrument still shows this message, switch off power supply for this unit and contact MST for further instructions.

---- FAULT ----
NO SENSOR !

Fault - No Sensor !

This message indicates that no sensor is inserted or that a sensor type not suitable for the Satellite XT is used. To eliminate the problem, insert the correct sensor.

---- FAULT ----
WRONG SENSOR !

Fault - Wrong Sensor !

This message indicates that the sensor installed is not the sensor assigned to this particular instrument. To correct the problem, insert the sensor assigned and documented to this instrument. The data are stated in the test certificate provided with the shipment.

---- FAULT ----
REPLACE SENSOR!

Fault - Replace Sensor !

This message indicates that the sensor presently installed is depleted (the warning CHECK SENSOR ! has been ignored). To correct the problem, replace the old sensor immediately.

! This function is not available for instruments with oxygen sensor.

Fault - Extractive !

---- FAULT ----
EXTRACTIVE !

Only for instruments with Extractive Module.

This message indicates that there is a problem with the Extractive Module. Check power supply, sample tubing, sample tubing connections, and sample line filter. Perform any corrective action required.

If the message is still shown, please contact our service department for further instructions.

Fault - Pyrolyzer !

---- FAULT ----
PYROLYZER !

Only for instruments with Pyrolyzer Module.

This message indicates that there is a problem with the Pyrolyzer Module.

Please contact our service department for further instructions.

8.1 Sensor Order Information

Substance / Sensor	Part No. sensor	Nominal Range	Unit	Note	Dust Filter allowed
AsH3 Arsine (3 El.)	9602-6001	0 ... 1.00	ppm		yes
AsH3 Arsine (2 El.)	9602-6004	0 ... 1.00	ppm	1)	yes
AsH3 Arsine (2 El.)	9602-6002	0 ... 10.0	ppm	1)	yes
B2H6 Diborane	9602-6202	0 ... 1.00	ppm		yes
Br2 Bromine	9602-6800	0 ... 5.00	ppm		No
C4F6 Hexafluorobutadiene	9602-9732	0 ... 50.0	ppm	3)	no data
C5F8 Octafluorocyclopentene	9602-9730	0 ... 20.0	ppm	3)	no data
CH3F Methyl Fluoride	9602-9720	0 ... 0.500	% vol.	3)	no data
Cl2 Chlorine	9602-5300	0 ... 5.00	ppm		yes
ClF3 Chlorine Trifluoride	9602-7410	0 ... 1.00	ppm		No
ClO2 Chlorine Dioxide	9602-7400	0 ... 1.00	ppm		No
CO Carbon Monoxide	9602-5400	0 ... 500	ppm		yes
COCl2 Phosgene	9602-6600	0 ... 1.00	ppm		yes
DCE 1,2 Di-chloro-ethylene 1,2	9602-9600	0 ... 1000	ppm	3)	no data
C2H4O Ethylene Oxide	9602-8000	0 ... 20.0	ppm		no data
F2 Fluorine	9602-6400	0 ... 5.00	ppm		No
F2 Fluorine	9602-6401	0 ... 30	ppm		No
GeH4 Germane	9602-6902	0 ... 5.0	ppm		yes
H2 Hydrogen (1%)	9602-5100	0 ... 1.000	% vol.		yes
H2 Hydrogen (4 %)	9602-5101	0 ... 4.00	% vol.	2)	yes
H2S Hydrogen Sulfide	9602-5200	0 ... 100	ppm		yes
H2S Hydrogen Sulfide (org.)	9602-5201	0 ... 30.0	ppm	1)	yes
H2Se Hydrogen Selenide	9602-5601	0 ... 5.00	ppm		No
HBr Hydrogen Bromide	9602-7000	0 ... 30.0	ppm		No
HCl Hydrogen Chloride	9602-5800	0 ... 30.0	ppm		No
HCN Hydrogen Cyanide	9602-5700	0 ... 30.0	ppm		No
HF Hydrogen Fluoride	9602-6500	0 ... 10.0	ppm		No
HMDS Hexamethyldisilazane	9602-6714	0 ... 500	ppm		yes
HMDS Hexamethyldisilazane	9602-6715	0 ... 0.500	% vol.		yes
N2H4 Hydrazine	9602-7600	0 ... 1.00	ppm		yes
NF3 Nitrogen Trifluoride	9602-9700	0 ... 50.0	ppm	3)	no data
NH3 Ammonia (100 ppm)	9602-6704	0 ... 100	ppm		No
NH3 Ammonia (1000 ppm)	9602-6705	0 ... 1000	ppm	2)	No
NO Nitric Oxide	9602-7200	0 ... 250	ppm		yes
NO2 Nitrogen Dioxide	9602-7300	0 ... 25.0	ppm		yes
O2 Oxygen	9602-5500	0 ... 25.0	% vol.		yes
O3 Ozone	9602-7100	0 ... 1.00	ppm		No
O3 Ozone	9602-7101	0 ... 1.00	ppm	1)	No
continued overleaf					

Reference Information - Section 8

Substance / Sensor		Part No. sensor	Nominal Range	Unit	Note	Dust Filter allowed
PH3	Phosphine (3 El.)	9602-6102	0 ... 1.00	ppm		Sí
PH3	Phosphine (2 El.)	9602-6100	0 ... 1.00	ppm	1)	Sí
SF6	Sulfur Hexafluoride	9602-9710	0 ... 0.500	% vol.	3)	Sin datos
SiH4	Silane	9602-6301	0 ... 50.0	ppm		Sí
SO2	Sulfur Dioxide	9602-5900	0 ... 25.0	ppm		Sí
TEOS	Tetraethyl Orthosilicate	9602-7500	0 ... 100	ppm		No
TMB	Trimethyl borate	9602-7510	0 ... 500	ppm		No
TMP	Trimethyl phosphite	9602-7800	0 ... 30.0	ppm		Sí
	Notas:	1) Special application				
		2) Special range				
		3) Pyrolyzer Module required for detection				
		Further gases and ranges on request				

8.2 Spares and Accessories

Part Number	Description
9602.0050.10.03	Mounting Rail Standard
9602.0050.10.02	Mounting Plate DIN-Rail, Option
9602.0051.10.02	Mounting Plate L-shaped with DIN-Rail, Option
9602.0090.00.01	Sensor Extension, 2 meters
9602.0091.00.01	Sensor Extension, 3 meters
9602.0092.00.01	Sensor Extension, 1 meter
9602.0095.40.00	Calibration Cap
9902-4000	Duct Mounting Saddle Assy, 4 inches
9902-4010	Duct Mounting Saddle Assy, 6 inches
9902-4020	Duct Mounting Saddle Assy, 8 inches
9902-4030	Duct Mounting Saddle Assy, 10 inches
9902-4040	Duct Mounting Saddle Assy, 12 inches
9902-4100	Duct Mounting Saddle Assy, 1,5 inches
9902-4110	Duct Mounting Saddle Assy, 2 inches
9902-4120	Duct Mounting Saddle Assy, 2,5 inches
9902-4130	Duct Mounting Saddle Assy, 3 inches
9902-4200	Duct Mounting Saddle (Assy), flat

9.1 Principle of Operation

The Extractive Module XT is an add-on module for use in combination with the Satellite XT. It enables for keeping hazardous, difficult to reach, or otherwise inaccessible areas under continuous surveillance. It is capable of sampling areas up to 50 m away. Power is supplied via the Satellite XT. Status information is provided by the Satellite XT that provides the digital interface as well.

The module contains a diagnosis for electronics and pump. The correct gas flow is factory set and saved in the instrument. If there is a problem with the Extractive Module XT, the display of the Satellite XT shows the fault message FAULT EXTRACTIVE. For information on fault messages and instructions on how to correct a fault condition, please refer to Section 7, Troubleshooting.

9.2 General Instructions

Listed hereafter several aspects that should be reflected when locating monitoring point and instrument. When placing the sampling point, the property (lighter or heavier than air) of the target gas must be considered. The instrument should be mounted as close to the monitoring location as possible to minimize sample transport time. The area immediately surrounding the sample inlet at the monitoring point must be free from objects that might hinder free flow of air. The instrument should be installed away from any possible liquid sources, extreme dust and dirt sources and should be protected against rain and sunlight.

The sample line should be run as direct as possible to improve transport time. Avoid running the sample line through areas of great temperature extremes. The sample outlet must be connected to an exhaust line and must be properly vented. Both, sample and exhaust tubing must not be crimped or placed in an area where weight could collapse the tubing.

Dust may be a result of construction as well as manufacturing activities. If unusual quantities of dust are expected at the monitoring location, an appropriate filter for the sample line must be installed. The use of a dust filter depends on the target gas, refer to the table Sensor Order Information in Section 8, Reference Information, or contact our service department.

As excess amounts of dirt in the filters will reduce the sample flow and will thus affect concentration readings of the instrument, make sure to regularly change sample line filters (every 1 to 6 months, depending on the ambient conditions). For order information refer to Section 8, Reference Information, Spares and Accessories.

Moisture may occur as rain entering a line at an outdoor sampling location or as condensation from outdoor-to-indoor temperature fluctuations. In case of unusual quantities of moisture, appropriate steps must be taken to protect the instrument; consult us for respective assistance.

9.3 Safety Instructions

Never use compressed air to clean the tubing while it is connected to the instrument.

Use isopropanol and a soft cloth to clean the housing. Do not use any aggressive detergents.

! Note:

To extend an existing Satellite XT to an extractive system, please contact our service department. This modification makes it necessary to open the housing of the Satellite XT, which is only allowed for authorized persons.

9.4 Instrument Design

Front View showing Extractive Module XT connected to Satellite XT.

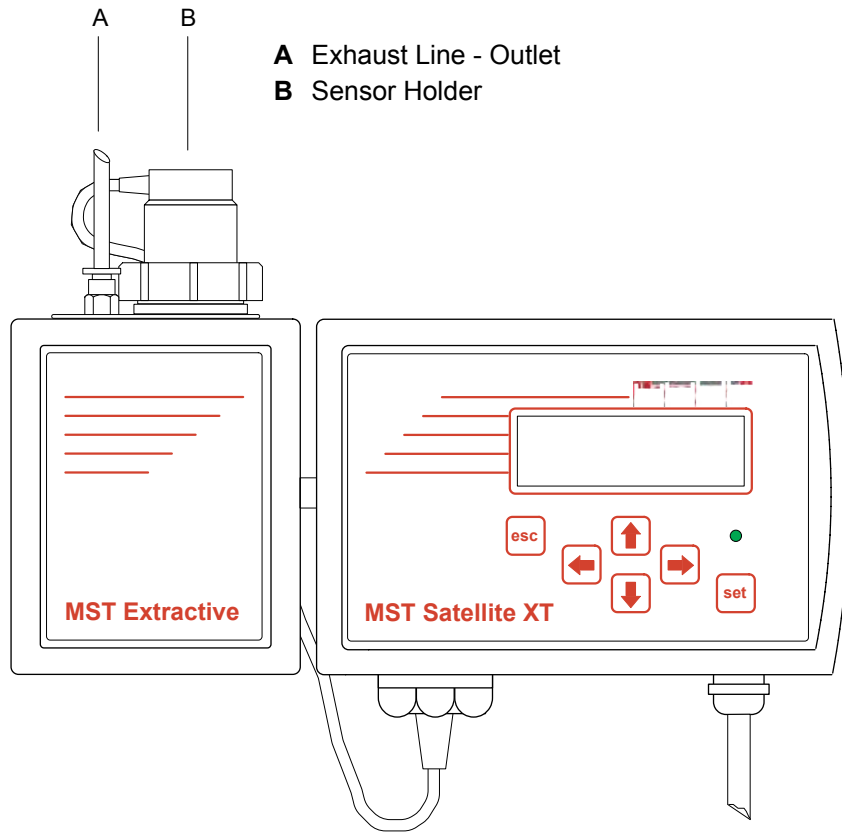

Extractive Module XT - Section 9

Side View (left)

- A Exhaust Line - Outlet
- B Sensor Holder
- C Sample Line - Gas Inlet

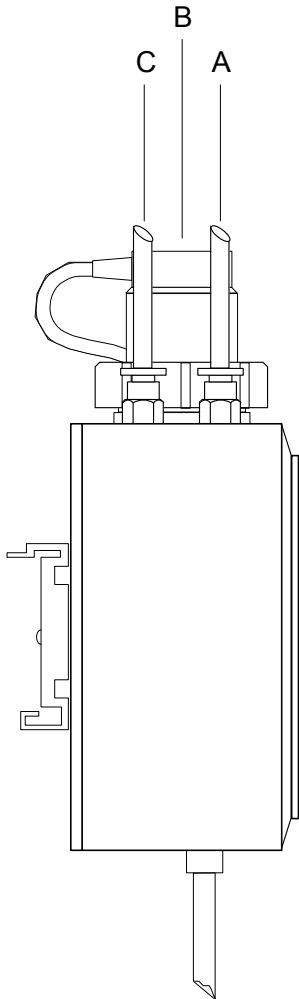

Side View (right)

- B Sensor Holder
- D Sensor Connection to Satellite XT
- E Connection Extractive Module XT and Satellite XT

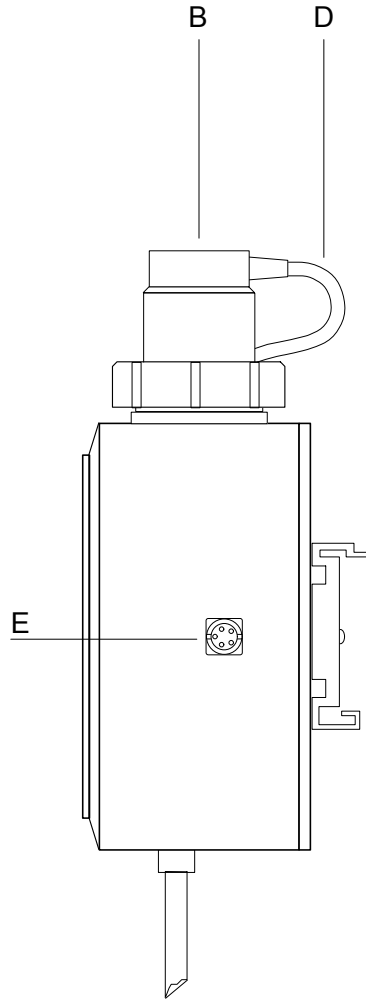

Top View (only Extractive Module XT)

- A Exhaust Line - Outlet
- B Sensor Holder
- C Sample Line - Gas Inlet
- D Sensor Connection to Satellite XT

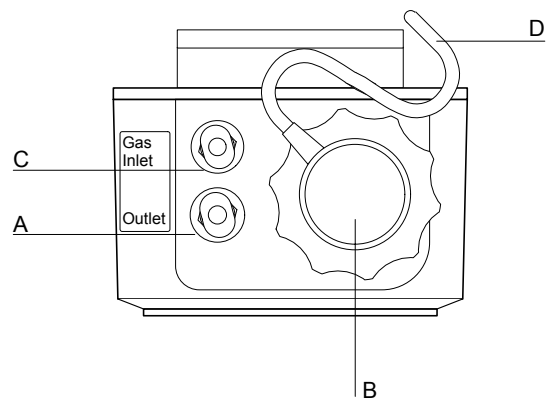

9.5 Mounting

The Extractive Module XT is prepared for DIN-rail mounting. An appropriate mounting rail is delivered with the instrument, which allows mounting the Extractive Module XT and the Satellite XT side by side.

Mount this rail to a wall with the appropriate fasteners and slide both modules onto it. Plug in male and female connector of Satellite XT and Extractive Module XT.

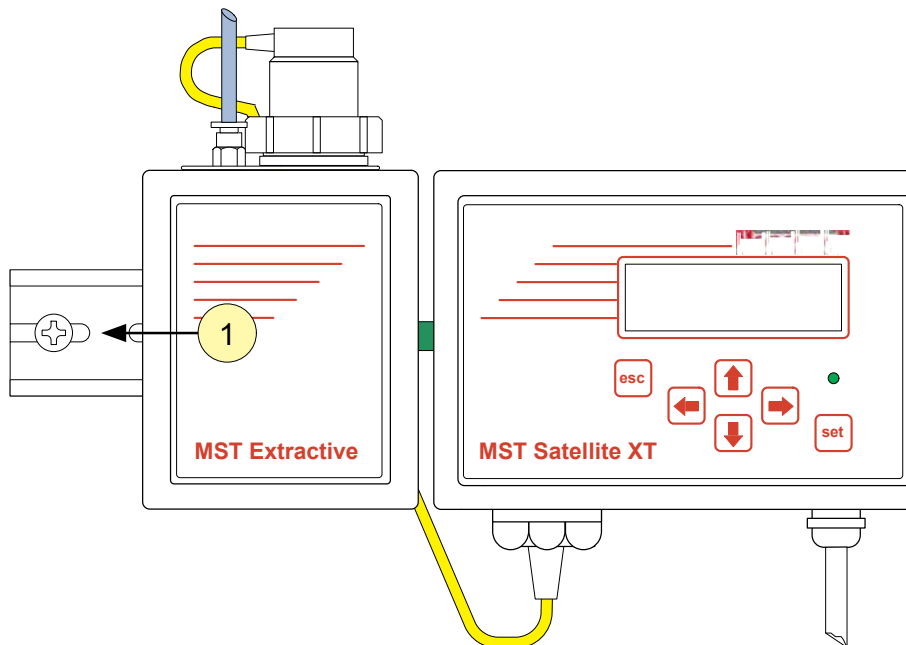

Module Connections

- sample tubing.
- sensor connection between Extractive Module XT and Satellite XT.
- Data link and power supply.

9.6 Tubing Connections

Tubing material is PTFE or PFA with an outer diameter of 1/4" and an inner diameter of 3/16". Length and inner diameter of the sample line will affect the response time. Length of the sample lines should be kept as short as possible. With a sample line ID of 3/16" (4.7 mm) and a length of 10 m, the delay in response does not exceed 30 seconds.

Sample Line Inlet

The fitting for connecting the sample line inlet is located on top of the housing and marked "Gas Inlet". Improper installation of the sample inlet tube may result in dilution or even complete loss of the sample.

Exhaust Line Outlet

The fitting for connection of the exhaust line outlet is located on top of the instrument and marked "Outlet". Since hazardous gas concentrations may still be present at the exhaust line outlet, it is recommended to connect the exhaust line to an exhaust duct.

Note: If the pump is operated at the maximum sample line distance of 50 m, the maximum exhaust line length is 25 m to avoid flow failure due to back pressure in the pump.

**Note:
Do not apply power until the system is ready for start-up.**

9.7 Sensor Replacement

This procedure is used to replace a depleted sensor by a fresh sensor. The replacement sensor must have the same part number as the installed sensor. Press the <esc> key on the Satellite XT keypad and enter the password to exit the Monitoring Mode. The green status LED of the Satellite XT is off, the instrument is not monitoring. A maintenance message is transmitted to the communication network.

Go to the Maintenance Menu and press the <set> key to enter.
 Go to the submenu Sensor Service and press the <set> key to enter.
 Follow the dialogue displayed at the bottom line of the screen - Figure 1.

Figure 1

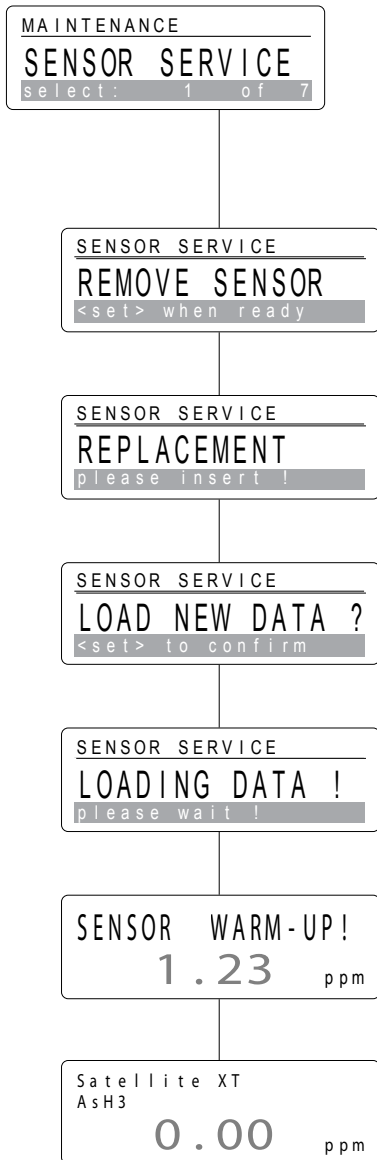

<REMOVE SENSOR>

Unscrew the gland nut (F) to remove the sensor holder (B) from the flow adapter of the Extractive Module XT - Figure 2. Remove the installed sensor (G) - Figure 3. Press the <set> key to continue. Unpack the replacement sensor and remove shorting device from the sensor plug, where necessary.

<REPLACEMENT>

Insert the new sensor (G) into the socket inside the sensor holder, aligning nose of the socket, groove of the sensor, and the arrow printed on the sensor label - Figure 4.

Insert the sensor holder (B) with the replacement sensor installed into the flow adapter of the instrument and fasten the gland nut (F) - Figure 5. Press the <set> key to continue.

<LOAD NEW DATA ?>

If you want the data of the new sensor to be loaded, confirm this message by pressing the <set> key.

<LOADING DATA !>

The instrument is now loading the new data from the sensor into the unit's internal memory.

<SENSOR WARM-UP>

A sensor warm-up is performed and the display of the Satellite XT shows the according message, until the displayed value is zero. The warm-up time required depends on the type of sensor. After the sensor warm-up, the instrument will automatically switch to the Monitoring Mode.

The Sensor Service procedure is also described in Section 4, Maintenance.

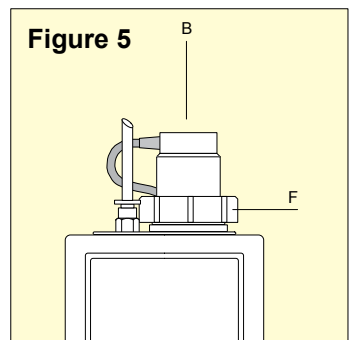
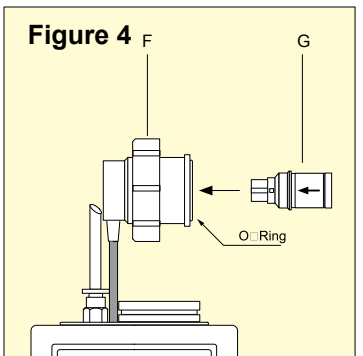
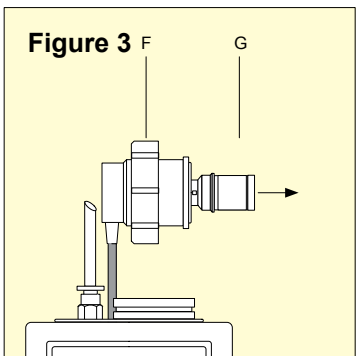
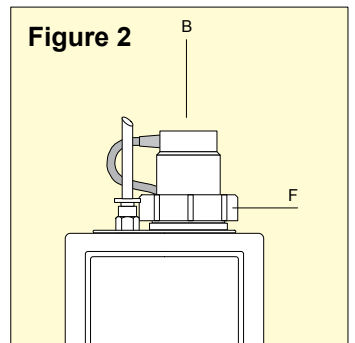

9.8 Technical Specifications

Power Requirements

voltage	power is provided by the Satellite XT, power supply range 18 - 24 VDC
consumption	max. 2.4 W

Physical Dimensions

size	78 x 95,5 x 50 mm	(W x H x D)
	3,1" x 3,8" x 2,0"	(W x H x D)
weight	500 g	
	17.6 oz	

Housing Protection Class IP 30

RFI / EMC EN 50270

Operating Conditions

sample tubing	OD 1/4" ID 3/16" PTFE or PFA
response time	< 30 sec. with a tubing length of 10m
temperature	0 °C ... +40 °C +32 °F ... +104 °F
pressure	700 ... 1300 hPa
humidity	20 ... 90 % r.h.
Maximum negative pressure (at pump)	-150mbar
Maximum sample line length	50 m (see note in section 9.6)
Recommended sample line length	10 m

Part Number

version for toxic/corrosive gases (except C ₅ F ₈ and SF ₆)	20404-0200
version for combustible gases	20404-0250
version for C ₅ F ₈ and SF ₆	20404-0300

Warning:

Extractive Module 20404-0200 must only be used with Pyrolyzer Modules 20408-0110, 20408-0112, 20408-0116 and 20408-0122.

Extractive Module 20404-0300 must only be used with Pyrolyzer Modules 20408-0114 and 20408-0120.

10.1 Principle of Operation

The Pyrolyzer Module XT is an add-on module for monitoring gases requiring pyrolytic sample preparation for detectability. It requires both, a Satellite XT and an Extractive Module XT. The connected Satellite XT displays the module's status of operation and provides the digital interface.

Each instrument is only configured for monitoring the substance specified on the identification label. The instrument is delivered with a certain sensor installed. Reference for assignment of instrument and sensor is the serial number. These data are also documented in the Certificate of Quality Control provided with the shipment. Instrument and sensor have been gas calibrated and these specific calibration parameters are stored in the integrated data memory of sensor and instrument.

Make sure to use only sensors for the substance specified on the module's identification label. Use only sensors designed for use with the Pyrolyzer Module XT.

The Pyrolyzer Module XT is powered by a wide range power supply. The module contains a diagnosis for electronics and filament. The filament voltage is factory set and saved in the instrument. If there is a problem with the Pyrolyzer Module XT, the display of the Satellite XT reads FAULT PYROLYZER. Information on fault messages and instructions on how to correct a fault condition, are provided in Section 7, Troubleshooting.

10.2 General Instructions

Listed hereafter are several aspects that should be reflected when locating monitoring point and instrument. When placing the sampling point, the property (lighter or heavier than air) of the target gas must be considered. The instrument should be mounted as close to the monitoring location as possible to minimize sample transport time. The area immediately surrounding the sample inlet at the monitoring point must be free from objects that might hinder free flow of air. The instrument should be installed away from any possible liquid sources, extreme dust and dirt sources and should be protected against rain and sunlight.

The instrument must be mounted in an upright position. The ventilation apertures on top and rear of the the housing must not be covered. The instrument must be easily accessible for operation and there must be sufficient space above the instrument to allow sensor replacement or to open the housing for maintenance purposes.

The sample line should be run as direct as possible to improve transport time. Avoid running the sample line through areas of great temperature extremes. The sample outlet must be connected to an exhaust line and must be properly vented. Both, sample and exhaust tubing must not be crimped or placed in an area where weight could collapse the tubing.

10.3 Safety Instructions

Always disconnect the Pyrolyzer Module XT from mains power before you open the housing.

The vents on top and rear of the instrument must not be covered. Do not enter any tapered or sharp items into the vents.

Use isopropanol and a soft cloth to clean the housing. Do not use any aggressive detergents.

Never use compressed air to clean the tubing when connected to the instrument. This will destroy the internal pressure switch.

WARNING: The Pyrolyzer Module XT will not respond to the target gas in conditions of less than 20 % r.h. Observe the specified operating conditions for humidity.

10.4 Instrument Design

The Pyrolyzer Module XT can only be operated in combination with the Satellite XT and the Extractive Module XT. All three modules are prepared for DIN-rail assembly.

Figure 1: Side view of the Pyrolyzer Module only.

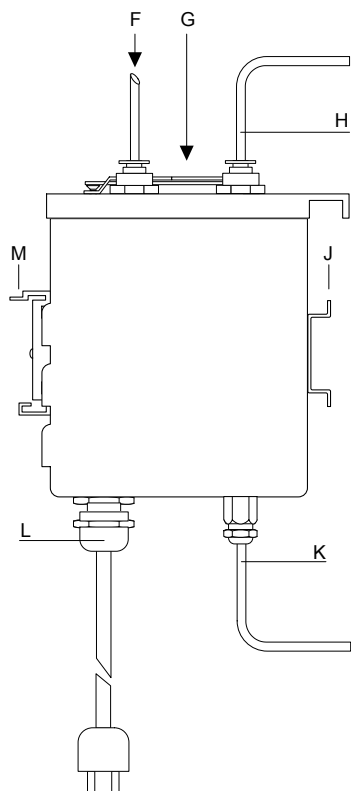

Figure 2: Front view of the complete assembly Pyrolyzer Module, Extractive Module, and Satellite XT.

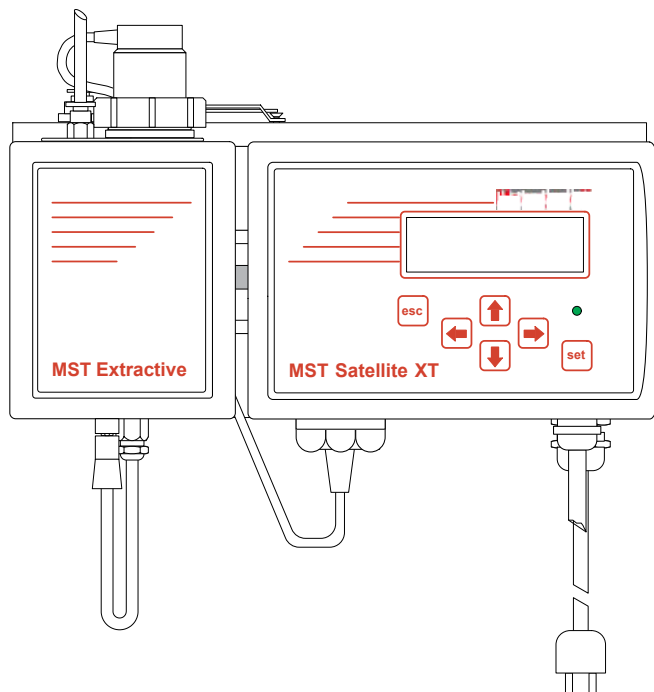
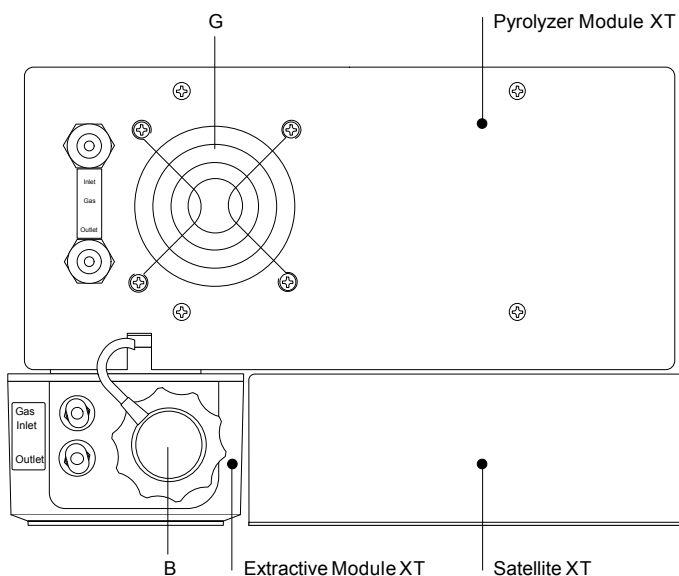

Figure 3: Top View of the complete assembly



B Sensor Holder

F Sample Line - Inlet

G Vent

H Sample Line - connection to Extractive Module XT

J DIN-rail

K Data Link - Pyrolyzer Module XT to Extractive Module XT

L Power Fitting

M Adapter for DIN-rail

10.5 Mounting

The Pyrolyzer Module XT is prepared for DIN-rail assembly. An appropriate mounting rail is delivered with the instrument. Mount this rail to a flat surface with the appropriate fasteners.

When the rail is mounted, follow the steps below:

1. Slide the Pyrolyzer Module XT onto the rail mounted to the wall, see Figure 4.

Figure 4

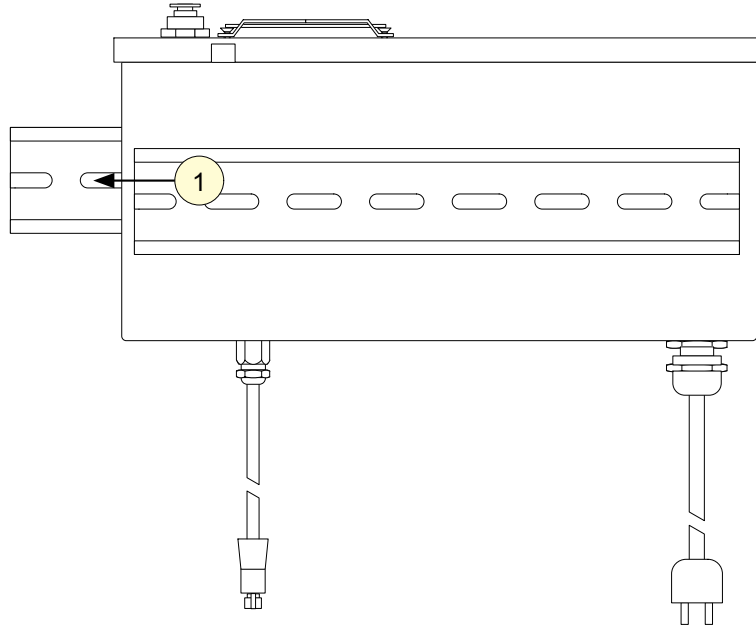

2. Slide the Extractive Module XT onto the rail at the front of the Pyrolyzer Module XT, see Figure 5.
3. Slide the Satellite XT onto the rail at the front of the Pyrolyzer Module XT, as illustrated in Figure 5.
4. Plug in male and female connector of Satellite XT and Extractive Module XT. See also Section 9, Extractive Module XT Installation.

Figure 5

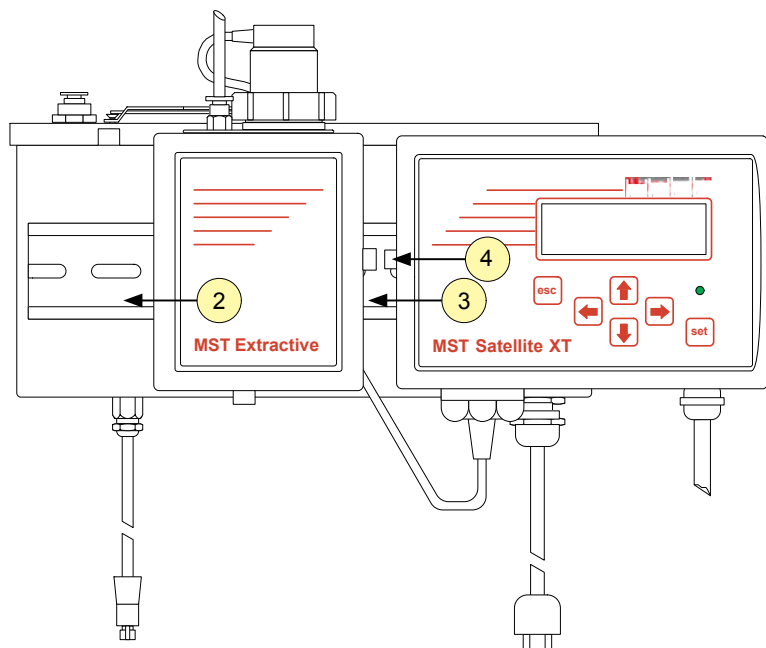

10.6 Tubing Connections

Tubing material is PTFE or PFA with an outer diameter of 1/4" and an inner diameter of 3/16". Length and inner diameter of the sample line will affect the response time. Length of the sample lines should be kept as short as possible. With a sample line ID of 3/16" (4.7 mm) and a length of 10 m, the delay in response does not exceed 30 seconds.

Moisture may occur either as rain entering a line at an outdoor sampling location or as condensation from outdoor-to-indoor temperature fluctuations. In case of unusual quantities of moisture, appropriate steps must be taken to protect the instrument; consult us for respective assistance.



Sample Line Inlet

The fitting for connecting the sample line inlet is located on top of the housing and marked "Inlet". Improper installation of the sample inlet tube may result in dilution or even complete loss of sample.

Sample Line Filter

Dust may be a result of construction as well as manufacturing activities. If unusual quantities of dust are expected at the monitoring location, an appropriate filter for the sample line must be installed. The use of a dust filter depends on the target gas, refer to the table Sensor Order Information in Section 8, Reference Information, or contact our service department. As excess amounts of dirt in the filters will reduce the sample flow and will thus affect concentration readings of the instrument, make sure to regularly change sample line filters (every 1 to 6 months, depending on the ambient conditions). For order information refer to Section 8, Reference Information, Spares and Accessories.

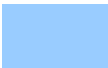
Module Connections

-  sample tubing.
-  sensor connection between Extractive Module XT and Satellite XT.
-  data link connecting Pyrolyzer Module XT and Extractive Module XT / Satellite XT.

10.7 Data Link

Plug the cable (pictured green) from the bottom plate of the Pyrolyzer Module into the connector in the bottom of the Extractive Module XT.

10.8 Power Connection

Use a standard power cable (obey any local regulations) and bring it through the power cable fitting into the module. Open the module from the top and connect

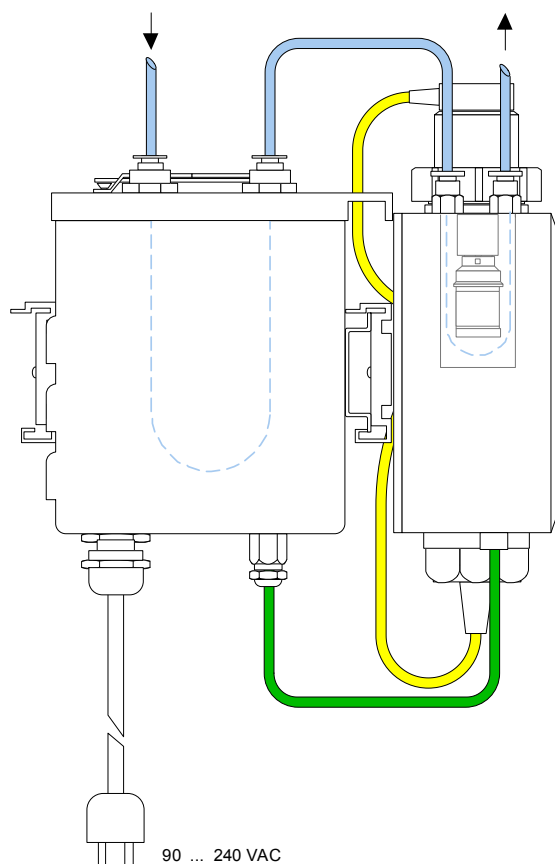

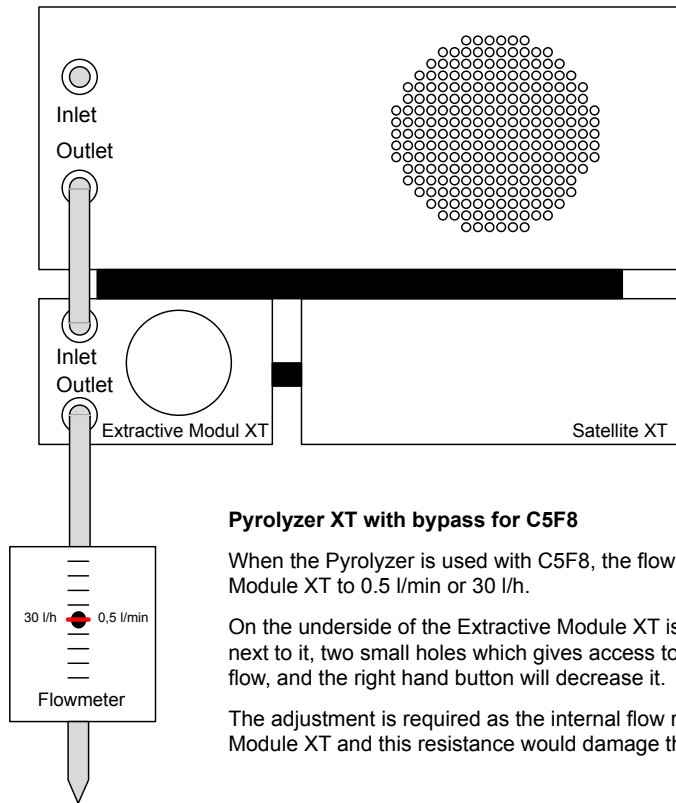

Pyrolyzer XT with bypass for C5F8

When the Pyrolyzer is used with C5F8, the flow needs to be adjusted at the outlet of the Extractive Modul XT to 0.5 l/min or 30 l/h.

On the underside of the Extractive Modul XT is the interconnection to the Pyrolyzer Module XT, and next to it, two small holes which gives access to two pushbuttons. The left hand button will increase the flow, and the right hand button will decrease it.

The adjustment is required as the internal flow resistance is different to the other types of the Pyrolyzer Modul XT and this resistance would damage the Extractive Modul XT.

10.9 Technical Specifications

Power requirements

Voltage	90 ... 240 VAC
Consumption	approx. 22 W / 2.13 A

Physical dimensions

Size:	223 x 97 x 100 mm (W x H x D) 8,8" x 3,8" x 3,9" (W x H x D)
Weight:	1800 g 4 lbs

Housing Protection Class IP 30

RFI / EMC EN 50270
EN 61010-1

Operating Conditions

Sample tubing	OD 1/4" ID 3/16"
Response time	< 30 sec. with a tubing length of 10m
Temperature	0 °C ... +40 °C +32 °F ... +104 °F
Pressure	700 ... 1300 hPa
Humidity	20 ... 90 % r.h.

Note: For applications where the humidity is less than 20 % r.h., consider using the MST Sample Conditioning System - Humidifier, part number 20408-4010.

Minimum Oxygen content of sample	3 %v/v
----------------------------------	--------

Part Numbers

Pyrolyzer Module XT NF3	20408-0110
Pyrolyzer Module XT 1,2-DCE	20408-0112
Pyrolyzer Module XT SF6	20408-0114
Pyrolyzer Module XT CH3F	20408-0116
Pyrolyzer Module XT C5F8	20408-0120
Pyrolyzer Module XT C4F6	20408-0122

Warning:

Pyrolyzer Modules 20408-0110, 20408-0112, 20408-0116 and 20408-0122 must only be used with Extractive Module 20404-0200.

Pyrolyzer Modules 20408-0114 and 20408-0120 must only be used with Extractive Module 20404-0300.

Find out more

www.honeywellanalytics.com

Contact Honeywell Analytics:**Europe, Middle East, Africa, India**

Life Safety Distribution AG
Javastrasse 2
8604 Hegnau
Switzerland
Tel: +41 (0)44 943 4300
Fax: +41 (0)44 943 4398
India Tel: +91 124 4752700
gasdetection@honeywell.com

Americas

Honeywell Analytics Inc.
405 Barclay Blvd.
Lincolnshire, IL 60069
USA
Tel: +1 847 955 8200
Toll free: +1 800 538 0363
Fax: +1 847 955 8210
detectgas@honeywell.com

Asia Pacific

Honeywell Analytics Asia Pacific
#701 Kolon Science Valley (1)
43 Digital-Ro 34-Gil, Guro-Gu
Seoul 152-729
Korea
Tel: +82 (0)2 6909 0300
Fax: +82 (0)2 2025 0388
analytics.ap@honeywell.com

Technical Services

EMEA: HAexpert@honeywell.com
US: ha.us.service@honeywell.com
AP: ha.ap.service@honeywell.com

www.honeywell.com

Please Note:

While every effort has been made to ensure accuracy in this publication, no responsibility can be accepted for errors or omissions. Data may change, as well as legislation, and you are strongly advised to obtain copies of the most recently issued regulations, standards, and guidelines. This publication is not intended to form the basis of a contract.

Issue 4 08/2013
H_MAN0860_EMEAI
2401M3007 ECO A03534
© 2013 Honeywell Analytics

The Honeywell logo is displayed in a bold, red, sans-serif font.

DSA Suppliers

Thank you for reading this. For pricing or further information, please contact us.

W: <https://dsasuppliers.com>

E: sales@dsasuppliers.com

P: +441158390391

Leading UK Supplier
Brand New & Genuine OEM Parts
Delivered Worldwide



Worldwide Delivery



1000+ Genuine Parts & Equipment

Please Note - The information, product designs & specifications in this document are subject to change without notice.
DSA Suppliers is not responsible for determining the suitability of this product.