



**Midas® Gas Detector
High-Temperature Pyrolyzer Option
(MIDAS-T-HTP)**

1. Introduction

The MIDAS-T-HTP pyrolyzer option is installed underneath the standard Midas® gas detector. The air sample is drawn through the pyrolyzer to the sensor cartridge. The pyrolyzer converts perfluorocompounds (PFCs) present in the air sample into hydrogen fluoride (HF) by means of pyrolysis. The HF can then be measured by the sensor and the concentration displayed as the equivalent reading in ppm.

NOTE: To maintain stated sensor accuracy when using the pyrolyzer, ensure ambient temperature of installation point does not exceed 30°C (86°F). It is recommended that the ventilated Midas® top cover part number MIDAS-A-039 is used in all pyrolyzer applications. Usage above this temperature may require more frequent bump testing or calibration to confirm working specification.

(Contact Honeywell Analytics for the availability of other detectable gases using this pyrolyzer module)

2. Fitting the pyrolyzer module

See reverse for all diagrams

1. Isolate power to the detector.
2. Unscrew the captive thumbscrew located on the front panel.
3. Remove the cover by pulling it forward off the main chassis (See Diagram 1).
4. Unscrew the two captive retaining screws located at the bottom front of the chassis.
5. Pull the main chassis forward to disconnect it from the mounting bracket assembly (See Diagram 2).
6. Thread the connector and wire harness from the pyrolyzer through the rectangular access in the bottom of the mounting bracket and secure wires with retention clip (if available).
7. Plug the connector into the socket (con5) at the bottom left of the terminal board.

8. Offer the pyrolyzer module up underneath the mounting bracket ensuring that the fitting at the top rear of the pyrolyzer mates with the sample inlet port at the bottom of the mounting bracket.
9. Align the three screw mounting bosses on the top of the pyrolyzer with the three screw holes in the mounting bracket.
10. Insert and tighten the three screws provided (See Diagram 3).

3. Reassembling the Midas® detector

1. Align the PCB at the top rear of the main chassis with the connector at the top of the mounting bracket.
2. At the same time, align the two tubes at the bottom rear of the main chassis with the two tubes located on the bottom of the mounting bracket.
3. Slide the chassis backwards on the mounting bracket assembly so that the PCB, connector and tubes engage fully by firmly pushing the main chassis horizontally backwards on the mounting bracket.



WARNING:

DO NOT PUSH ON THE LCD AS THIS MAY CAUSE DAMAGE.

4. Align the two fixing screws located at the bottom of the chassis with the screw threads on the mounting bracket.

5. Tighten the screws to secure the chassis to the mounting bracket.
6. Fit the MIDAS-S-CFX sensor cartridge into the sensor cartridge chamber (See Diagram 4, and refer to the Sensor Cartridge Installation Quick Start Guide MIDAS-A-021).
7. Set the power switch to the “on” position.
8. Refit optional Midas® ventilated top by aligning the slots on either side with locating tabs on the mounting bracket assembly and push the cover horizontally until seated.
9. Tighten thumbscrew on the front panel (See Diagram 5)

4. Configuration

1. After completion of the startup sequence, press the ‘▲’ button for a few seconds to select the setup menu.
2. Enter the passcode (if set).
3. Use the ‘▲’ or ‘▼’ buttons to select the set up menu ‘’ icon and press the ‘✓’ to accept.
4. Use the ‘▲’ or ‘▼’ buttons to select the set alarms ‘’ submenu and press ‘✓’ to accept.
5. The flashing gas ID code is displayed along with the gas cylinder and alarms icon ‘’.
6. Use the ‘▲’ or ‘▼’ buttons to change the gas ID number to the appropriate PFC gas. See the manual for further details.
7. Continue to accept or change the rest of the alarm settings. *
8. Press ‘✓’ to update all changes (UPdt displayed).
9. Press ‘X’ twice to return to normal operation.

* For further details regarding the Midas® pyrolyzer option, refer to the Midas® operating manual MIDAS-A-001.

Find out more
www.honeywellanalytics.com

Contact Honeywell Analytics:

Europe, Middle East, Africa, India

Life Safety Distribution AG
Wilstrasse 11-U31
CH-8610 Uster
Switzerland
Tel: +41 (0)44 943 4300
Fax: +41 (0)44 943 4398
gasdetection@honeywell.com

Americas

Honeywell Analytics Inc.
405 Barclay Blvd.
Lincolnshire, IL 60069
USA
Tel: +1 847 955 8200
Toll free: +1 800 538 0363
Fax: +1 847 955 8208
detectgas@honeywell.com

Asia Pacific

Honeywell Analytics Asia Pacific
#508, Kolon Science Valley (I)
187-10 Guro-Dong, Guro-Gu
Seoul, 152-050,
Korea
Tel: +82 (0)2 2025 0300
Fax: +82 (0)2 2025 0329
analytics.ap@honeywell.com

Technical Services

ha.emea.service@honeywell.com
www.honeywell.com

Please Note:
While every effort has been made to ensure accuracy in this publication, no responsibility can be accepted for errors or omissions. Data may change, as well as legislation, and you are strongly advised to obtain copies of the most recently issued regulations, standards, and guidelines. This publication is not intended to form the basis of a contract.

Diagram 1:
Removing the Midas® cover

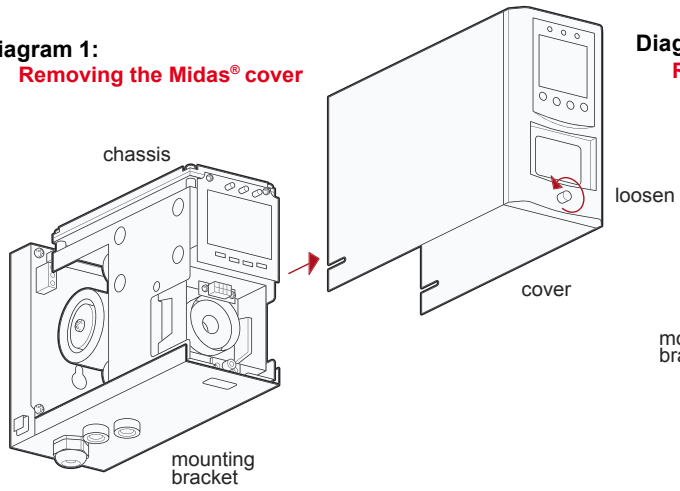

Diagram 2:
Removing the main chassis

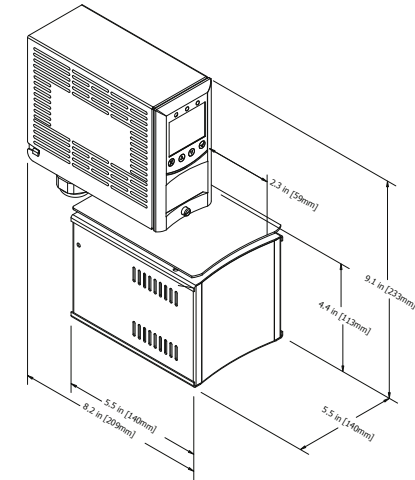
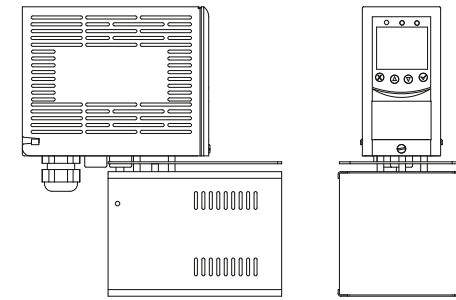
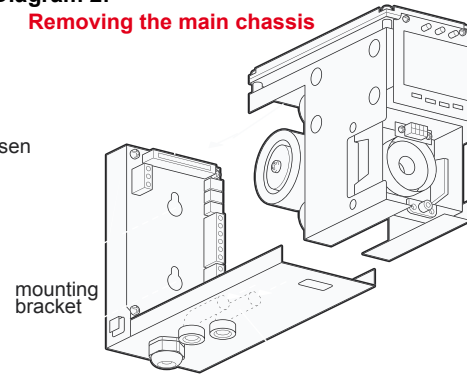

Diagram 3:
Fitting the pyrolzer module

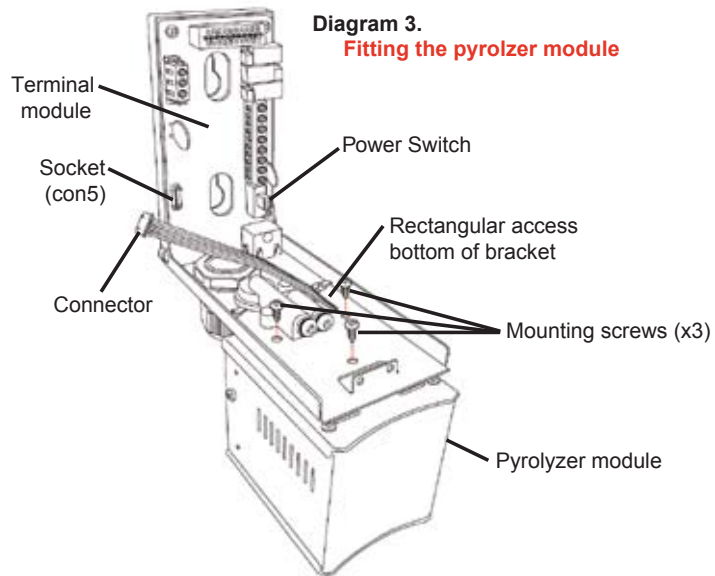

Diagram 4:
Fitting sensor cartridge

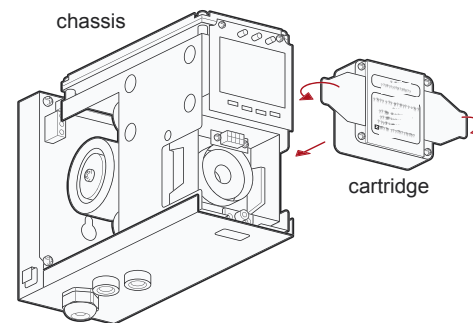

Diagram 5:
Fitting cover

